



GUIDE

1

BUILD GUIDE

mapleMaker

ADDITIVE ENGINEERING



SECTION



<i>1.1 Introduction</i>	<i>2</i>
<i>1.2 Table of Contents</i>	<i>3</i>
<i>1.3 Required Tools</i>	<i>4</i>
<i>1.4 Reseller Information</i>	<i>5</i>
<i>1.5 Components</i>	<i>6</i>

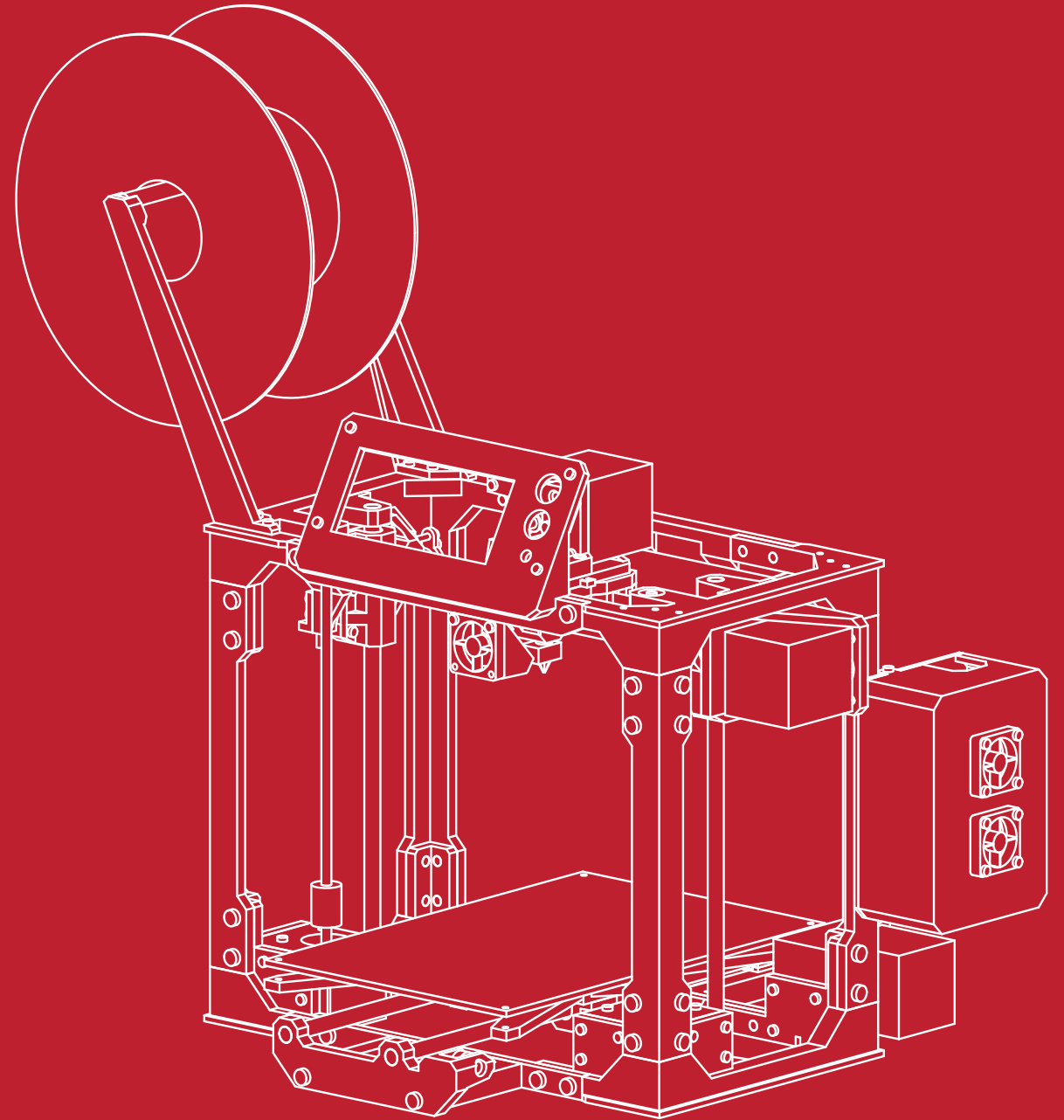

Welcome, and Thank you!

Thank you for your interest in the mapleMaker Mini V2 3D Printer.

The **mapleMaker Mini** introduces you to the world of additive manufacturing and 3D printing. With your own 3D printer, your concepts and design ideas can be translated from computer drawings to physical objects in short period of time.

The goal of this guide is to **introduce you to the parts and pieces** that will be required before you can assemble your printer kit. Most of these items can be sourced both locally and from any number of online retailers.

The aim of this kit was to reduce costs and create an **accessible, hackable, upgradeable, and ultimately, user customizable 3D Printer**. We believe that a 3D printer should evolve with it's users needs and knowledge, and become a platform for any number of future upgrades and additions without the need for costly re-works or additional components.

Ultimately though, we want to empower the next generation of designers, developers, and engineers by giving them the platform and tools to suite their needs for today, tomorrow, and well into the future.

We are Open Source. Collaboration fuels Innovation. Create, Innovate, and Share.

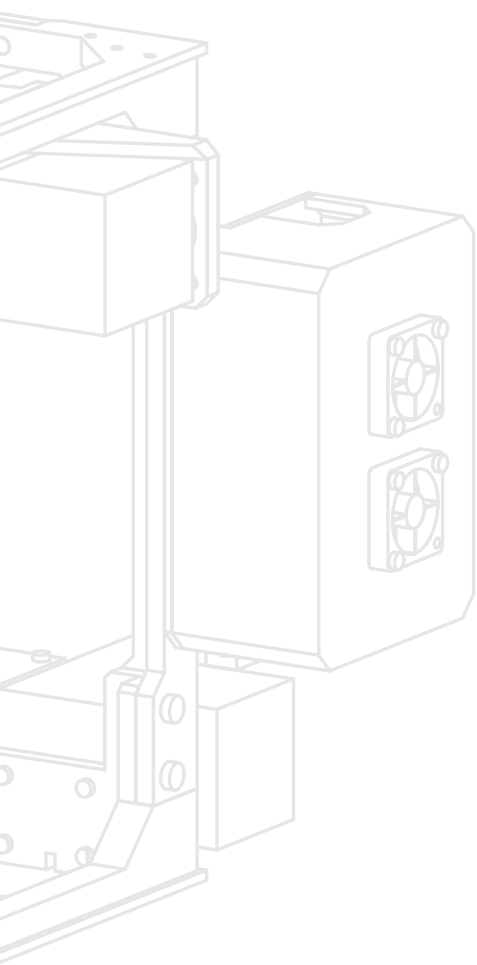

This guide is broken into several sections which encompasses the build process of the maplePrint Mini 3D printer. The process begins with the basic frame assembly and finishes with the final wiring and installation.

While we try to maintain the most up to date diagrams and illustrations, there may be slight differences between the illustrations contained within this guide, and the printed parts in your kit. If there are major changes or differences between the instructions contained within and the printed parts, you should have received an updated insert in your kit containing the revised instructions.

Section A:

1.1 Introduction	2
1.2 Table of Contents	3
1.3 Required Tools	4
1.4 Reseller Information	5
1.5 Components	6

Section B:

2.1 Z Motor Assembly	16
2.2 Lower Frame Assembly	18
2.3 Upper Frame Assembly	24
2.4 Lower/Upper Frame Union	26

Section C:

3.1 Extruder Assembly	34
-----------------------	----

Section D:

4.1 X-Carriage Assembly	48
4.2 Y Carriage Assembly	62
4.3 Print Bed Assembly	76
4.4 Z Carriage Assembly	82

Section E:

5.1 GT2 Belt Installation	98
5.2 LCD Installation	102
5.3 RAMPS Installation	106
5.4 Upper Bed Installation	116
5.5 Wiring & Final Configuration	118

Section F:

6.1 Appendix	136
--------------	-----

Before we begin the assembly process, it is vital that we have the proper tools to complete the build. Thankfully though, there are only a few tools required for the build. These tools were either included with your kit, or available at any local hardware or tool store.

You will need the following:

#2.5 Allen Key (for use with M3 screws)

#3 Allen Key (for use with M4 screws)

#4 Allen Key (for use with M5 screws)

Ceramic screw driver (for adjusting RAMPS drivers)

Spatula (to remove printed parts from the print bed)

Exacto Knife (for trimming and cleaning parts)

Needle nose or similar pliers

Solder iron and solder

Nylon wire ties or zip ties (for securing wiring looms)

3M Blue painters tape (for printing with PLA)

Hot glue gun (to secure endstops)

Additional information regarding this build guide:

We've attempted to keep this build guide simple and easy to understand. We've broken the assembly into several sections, and each step into individual illustrations to simplify the build process further. Each illustrated step in this guide is also accompanied by a list of parts and hardware required to complete the step. The illustrations of fasteners in these lists are printed to scale and may be used to size the hardware included in your kit. Simply place a fastener on top of or next to the illustration to determine if its the correct one for the job!

Below is a list of resellers and manufacturers of the components used in the mapleMaker Mini 3D Printer.

Some components may be sourced from your local home improvement retailers or specialist hobby stores.

Electronics, motors & extruders

Folger Technologies, LLC:	www.folgertech.com
Active Surplus:	www.active123.com
EckerTech Inc:	www.eckertech.com
Misumi	www.us.misumi-ec.com/
Mixshop	www.mixshop.com
Filastruder	www.filastruder.com
SDP/SI CA	www.sdp-si.com/
Skyhunt	www.skyhunt.net
ROBOTDIGG	www.robotdigg.com
Voxel Factory	www.voxelfactory.com

Linear rods & movement

Folger Technologies, LLC:	www.folgertech.com
ROBOTDIGG	www.robotdigg.com
EckerTech Inc:	www.eckertech.com
Mixshop	www.mixshop.com

Fasteners

HD Supply Canada:	www.brafasco.com (minimums may apply)
Fastenal	www.fastenal.com (minimums may apply)

Misc. electronics

Digikey:	www.digikey.ca
McMaster-Carr	www.mcmaster.com (minimums may apply)

The following list comprises the components required to build your printer. For the purposes of this build, we have used ROBOTDIGG (www.robotdigg.com) to source the majority of the components. ROBOTDIGG offers almost every component required, minus fasteners and threaded rod. The hot end has been sourced through e3D's authorized distributor, Filastruder (www.filastruder.com)

NEMA 17 48oz Stepper Motor

Quantity: 3

URL: <http://www.robotdigg.com/product/206/Nema17-48mm-Stepper-Motor>

Unit Cost: \$9.50



NEMA 17 34oz Stepper Motor

Quantity: 2

URL: <http://www.robotdigg.com/product/28/NEMA14-34mm-0.8A-or-1.25A-stepper-motor>

Unit Cost: \$6.80



Flexible Coupling - 5mm to 5mm

Quantity: 2

URL: <http://www.robotdigg.com/product/83/Flexible-Coupling-5mm-Shaft-to-5mm-Screw>

Unit Cost: \$1.80



20 Tooth GT2 Pulley

Quantity: 2

URL: <http://www.robotdigg.com/product/166/2GT-20-Tooth-6.35mm-Bore-Pulley>

Unit Cost: \$1.85



Open Ended 6mm GT2 Belt (2 meters)

Quantity: 1

URL: <http://www.robotdigg.com/product/10/Open-Ended-6mm-Width-GT2-Belt>

Unit Cost: \$1.80



LMS8UU (Short) 8mm Linear Bearing

Quantity: 12

URL: <http://www.robotdigg.com/product/13/LM8UU-Linear-Bearing>

Unit Cost: \$0.60



623ZZ Ball Bearing

Quantity: 4

URL: <http://www.robotdigg.com/product/62/623ZZ-Ball-Bearing>

Unit Cost: \$3.60



Poloululu 4988 Stepper Drivers

Quantity: 4

URL: <http://www.robotdigg.com/product/120/A4988-stepper-driver>

Unit Cost: \$3.80



Endstop

Quantity: 3

URL: <http://www.robotdigg.com/product/141/Endstop,-Snap-Action-Limit-Switch-SS-5GL>

Unit Cost: \$0.60



RAMPS 1.4 Controller

Quantity: 1

URL: <http://www.robotdigg.com/product/121/Ramps-1.4-Board>

Unit Cost: \$12.80



Arduino Mega 2560

Quantity: 1

URL: <http://www.robotdigg.com/product/123/Arduino-Mega-2560-R3>

Unit Cost: \$15.80



RAMPS LCD Display

Quantity: 1

URL: <http://www.robotdigg.com/product/122/RAMPS-LCD2004-with-SD-Socket>

Unit Cost: \$12.80



30mm Cooling Fan

Quantity: 4

URL: <http://www.robotdigg.com/product/197/12V-3CMHotend-Cooling-Fan>

Unit Cost: \$1.50



12V 5A Power Supply

Quantity: 1

URL: <http://www.robotdigg.com/product/350/12V-5AAC/DC-Adapter-Power-Supply>

Unit Cost: \$5.00



NEMA 17 34oz Stepper Motor

Quantity: 2

URL: <http://www.robotdigg.com/product/28/NEMA14-34mm-0.8A-or-1.25A-stepper-motor>

Unit Cost: \$6.80



Thermistor Cable (1m)

Quantity: 1

URL: <http://www.robotdigg.com/product/188/2pin-1MLong-Thermistor-Cables-w/-Dupont-Connector>

Unit Cost: \$0.40



Endstop Cables (1m)

Quantity: 3

URL: <http://www.robotdigg.com/product/189/3pin-1MLong-Endstop-Cables-w/-Dupont-Connector>

Unit Cost: \$0.60



e3D Lite6 All Metal Hot End

Quantity: 1

URL: <http://www.filastruder.com/products/lite6>

Unit Cost: \$35.00



MK8 Extruder Drive Gear

Quantity: 1

URL: <http://www.robotdigg.com/product/242/MK8-Filament-Drive-Gear>

Unit Cost: \$3.00



Compression Spring (for Extruder & bed)

Quantity: 5

URL: <http://www.robotdigg.com/product/71/Compression-Spring-for-Heatbed-and-Extruder>

Unit Cost: \$2.00



762mm length Linear Rods (Pack of 6)

Quantity: 1

URL: <http://www.robotdigg.com/product/113/Rostock-Mini-492mm-Long-8mm-Diameter-Smooth-Rod-Pack>

Unit Cost: \$24.00



Allen Key Set

Quantity: 1

URL: <http://www.robotdigg.com/product/128/1.5,-2,-2.5,-3,-4-size-allen-key-with-ball-head-in-pack>

Unit Cost: \$2.00



Nylon Cable Ties (100 pack)

Quantity: 1

URL: http://www.robotdigg.com/product/127/Nylon-Cable-Ties-2.5*100mm-100pcs-n-3.6*200mm-100pcs-Pack

Unit Cost: \$1.80



Ceramic Screwdriver

Quantity: 1

URL: <http://www.robotdigg.com/product/181/Ceramicscrewdriver-for-A4988-stepper-driver>

Unit Cost: \$1.20



4GB SD Card

Quantity: 1

URL: <http://www.robotdigg.com/product/345/4GB-SDCard-for-3D-Printing>

Unit Cost: \$4.50



Fasteners & Threaded Rod:

You will also require the following fasteners and threaded rod to complete the build.

These items can be purchased from your local hardware retailer or online.



M3X10mm Socket Cap Screw **x135**

M3X20mm Socket Cap Screw **x8**

M3X16mm Socket Cap Screw **x8**

M4X10mm Socket Cap Screw **x1**

M4X16mm Socket Cap Screw **x2**

M5X12mm Socket Cap Screw **x60**

M4X40mm Socket Cap Screw **x1**

4mm - 0.7 Stainless Steel Threaded rod

4mm - 0.7 Flat nut **x3**

1

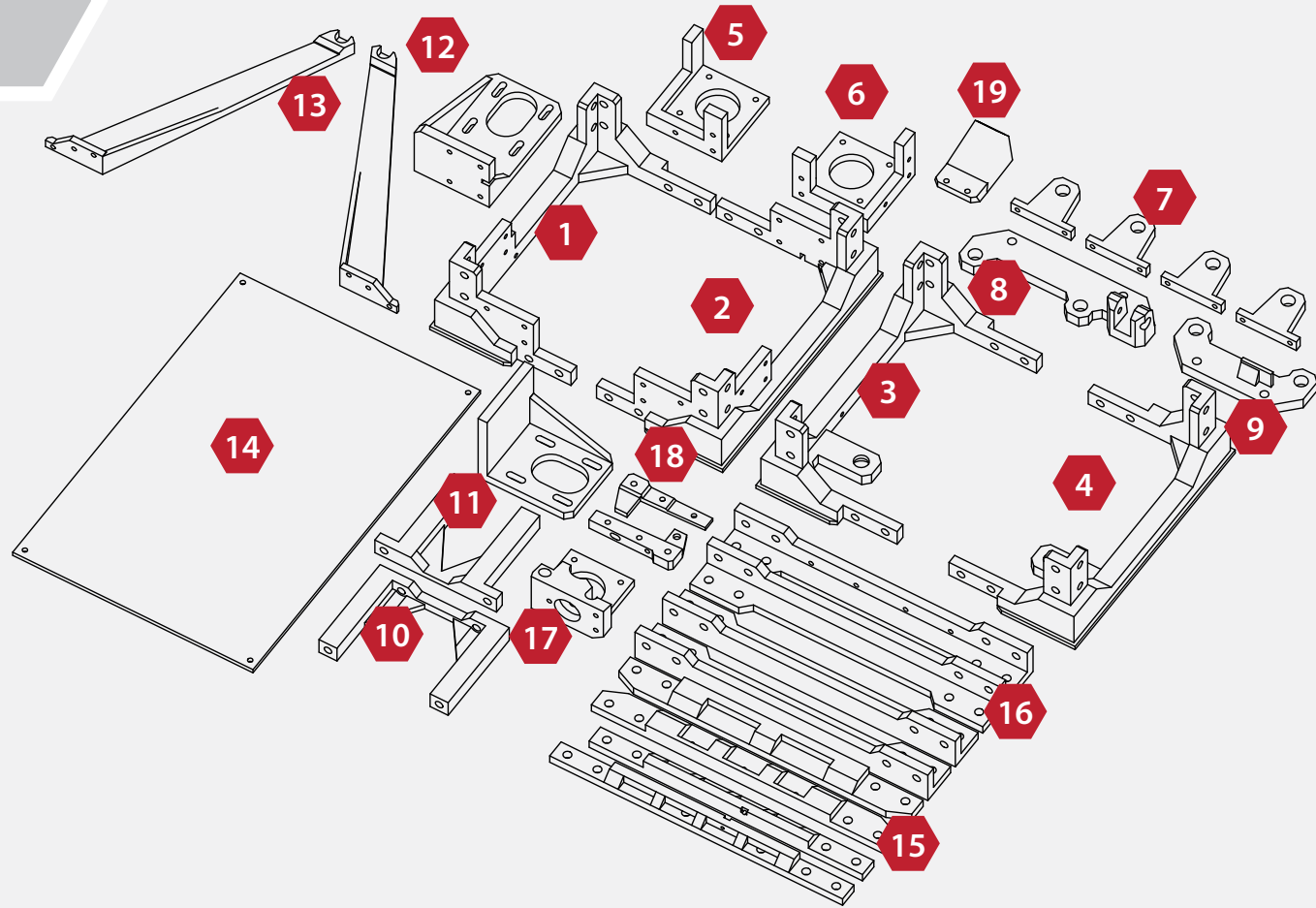

- 1. Left Lower Frame
- 2. Right Lower Frame
- 3. Right Upper Frame
- 4. Left Upper Frame
- 5. Left Z Motor Mount
- 6. Right Z Motor Mount
- 7. Z Axis Linear rod Mounts
- 8. Y Axis Carrier (Front)
- 9. Y Axis Carrier (Rear)
- 10. Y Axis Mount (Front)
- 11. Y Axis Mount (Rear)
- 12. Y Axis Motor Mount
- 13. Spool Holder Mounts (2)
- 14. Upper Bed (Printed)
- 15. Lower/Upper Frame rails (4)
- 16. Frame Upright Rails (4)
- 17. Extruder Mount
- 18. Extruder Idler Arm
- 19. Print Cooler Duct

2

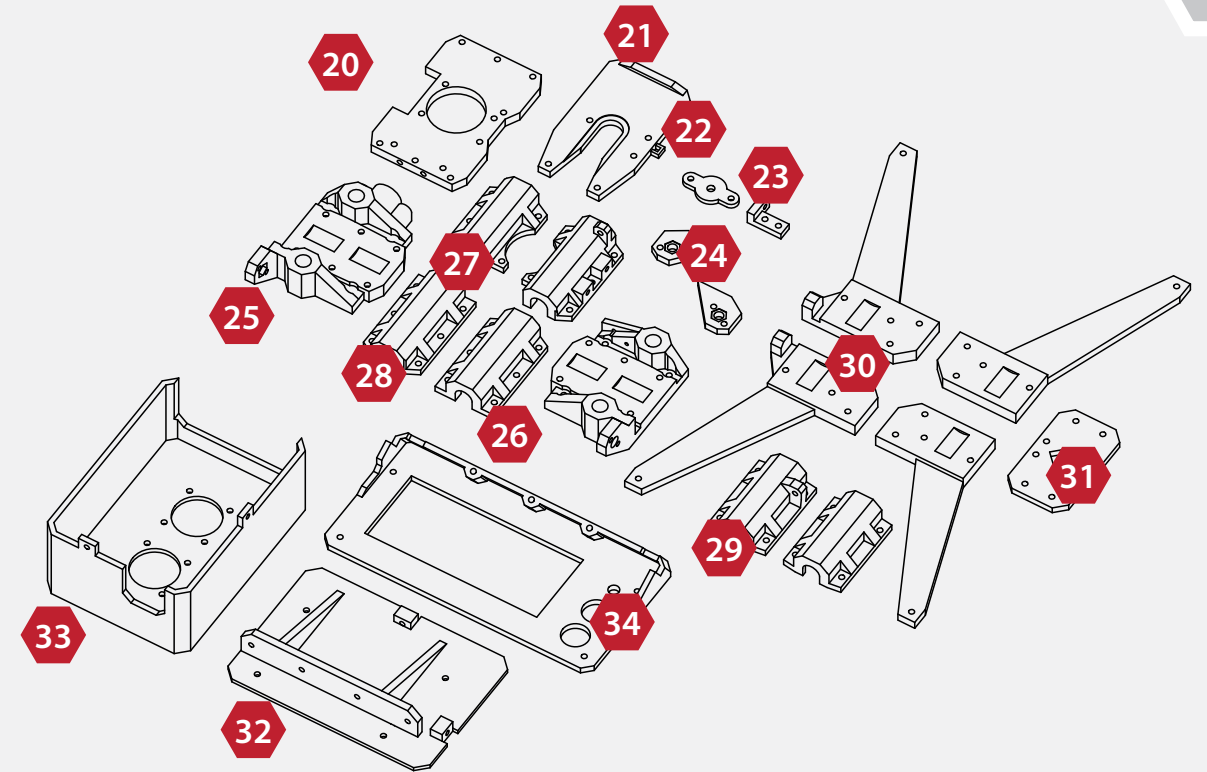

- 20. Extruder Base Mount
- 21. Hot-End Mount
- 22. X Axis Idler Cover
- 23. Z Axis Adjustment Mount
- 24. Z Axis Nut Covers
- 25. X Axis Assembly (Left)
- 26. X Axis Assembly (Right)
- 27. X (Extruder) Bearing Carriers (2)
- 28. Z Axis Bearing Carriers (2)
- 29. Y Axis Bearing Carriers (2)
- 30. Lower Bed Frame (4)
- 31. Lower Bed Union
- 32. Electronics Backplate
- 33. Electronics Enclosure
- 34. LCD Frame Assembly

SECTION

B

<i>2.1 Z Motor Assembly</i>	<i>16</i>
<i>2.2 Lower Frame Assembly</i>	<i>18</i>
<i>2.3 Upper Frame Assembly</i>	<i>24</i>
<i>2.4 Lower/Upper Frame Union</i>	<i>26</i>

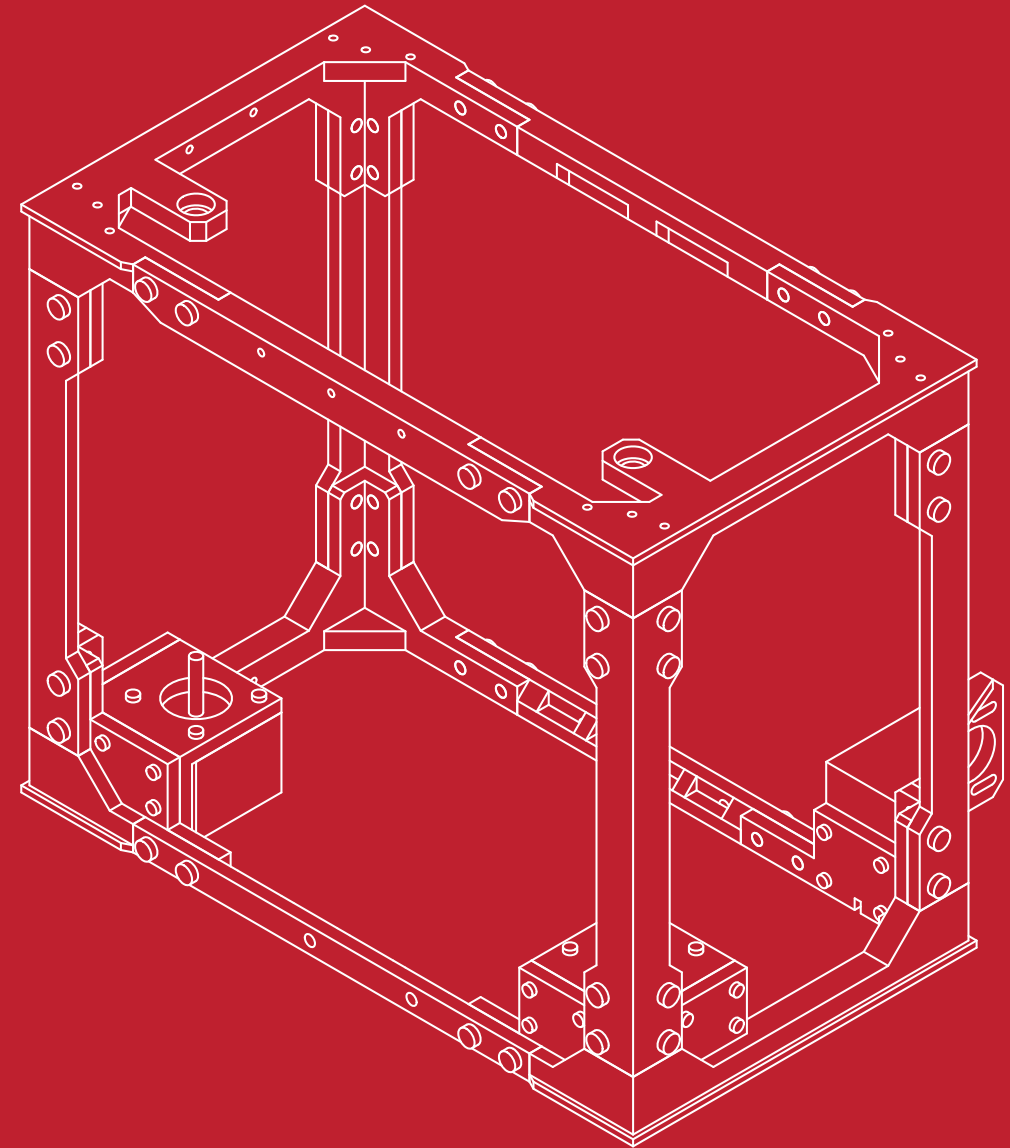

Z Motor Assembly (Right Front)

1

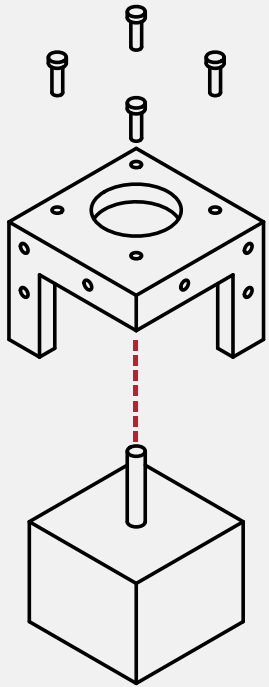

Locate the Hardware bag marked:
Z-Motor Mounts

Locate the **Right Front Motor mount**, the upright mounts should face the outside of the frame.

From the Stepper Motor package, select **1** of the **34mm (short) stepper motors**.

From the Fastener package, select:
4 M3x10 cap screws

X 4



Z Motor Assembly (Right/Left Front)

3

Using the **M3 Hex wrench**, screw the **4 M3 x 10 cap screws** through the **Right Front Motor** mount into the stepper motor.

Note: Take care not to over-tighten the screws, or you may break the motor mount.

Congratulations, the Right Front Z Motor Assembly is complete!

N/A

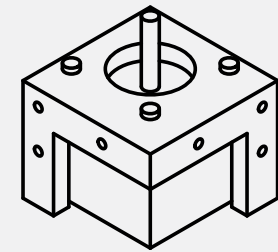

2

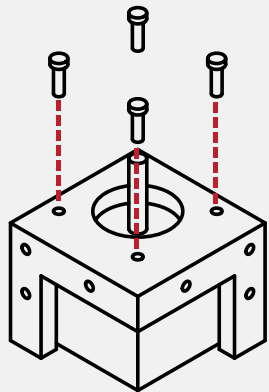

Insert the Stepper Motor into the base of the **Right Front Motor Mount**

The threads on the face of the Stepper Motor should align with the 4 holes of the Right Front Motor Mount.

N/A

Alert: Left Front Z Motor Assembly

Collect the **Left Front Motor Mount**, the **second 34mm (short) stepper motor** and **4 M3x10 cap screws**.

Repeat Steps 1-3 to complete the **Left Front Z Motor Assembly**

X 4

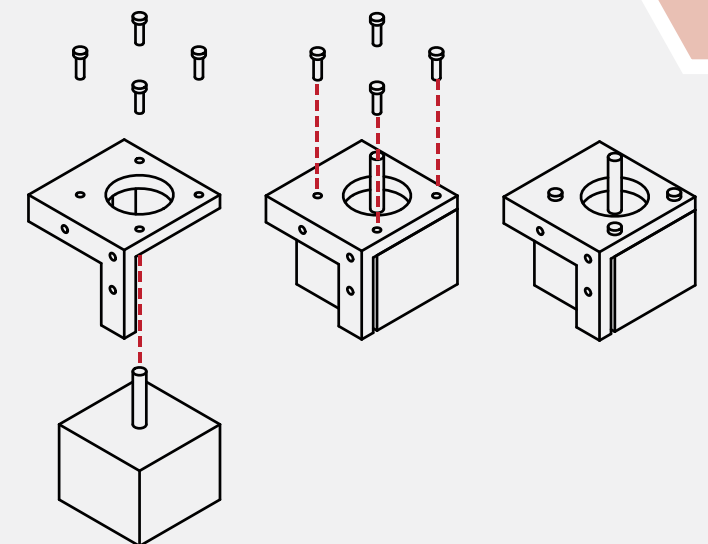

!

1

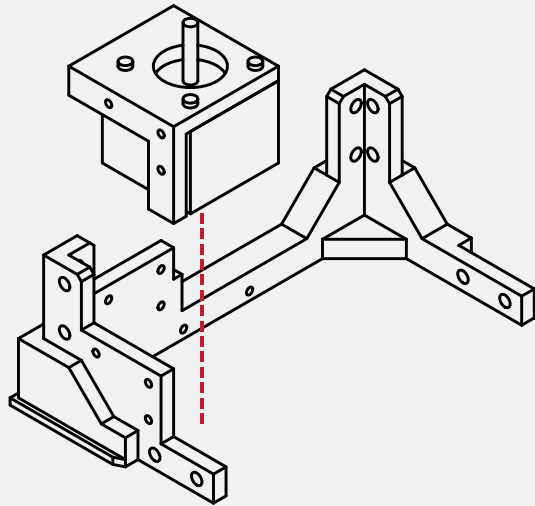

Locate the **lower left side frame**, and collect the left **Z motor assembly** completed in the previous steps.

Place the motor assembly into the lower left frame.

The screw holes on the motor assembly should match the screw holes in the lower left frame assembly.

N/A

2

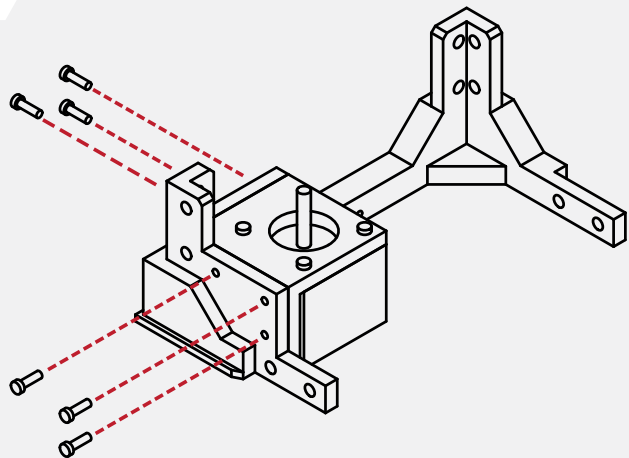

From the hardware bag, collect **6 M3 X 10** screws.

Using your **M3 Hex wrench**, attach the motor assembly to the lower frame assembly.

X 6



Congratulations, you've completed the left lower frame assembly.

Check the fit and ensure that all screws are tight.

Don't over tighten the screws, as this may strip the parts.

N/A

3

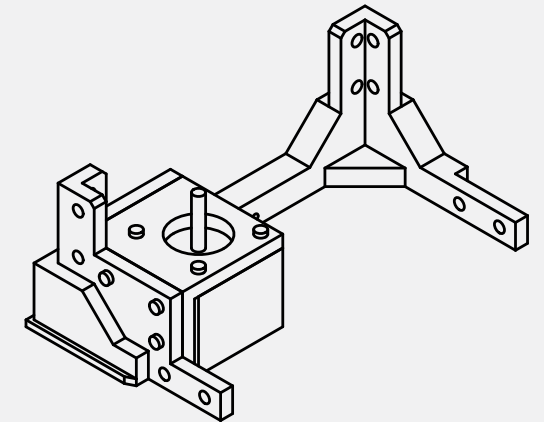

4

Locate the **Y axis motor mount** from your printed parts kit. This mount is longer than the similar X axis motor mount.

Also from your printed parts, locate the **lower right side frame**.

Check the fitment of both pieces before proceeding to the next step.

N/A

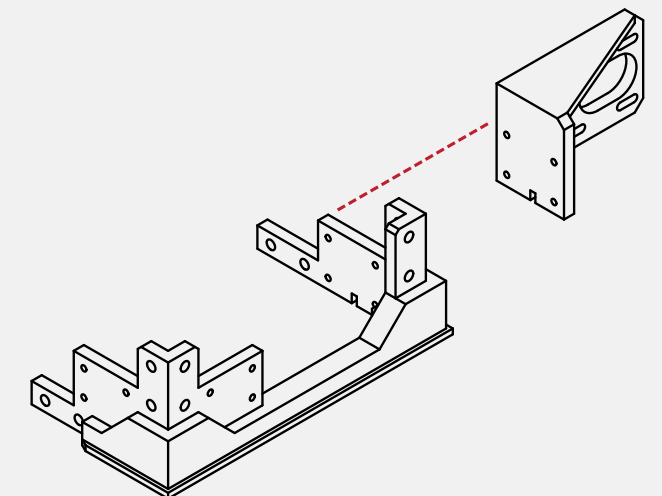

5

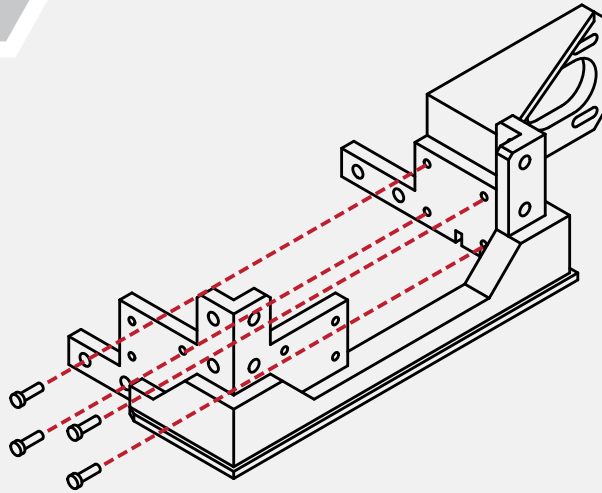

From the hardware bag, select **4 M3 X 10** screws.

Using the screws, attach the **Y axis motor mount** to the lower right side frame.

X 4



Locate the right **Z motor assembly** that was assembled in the previous steps.

Place the motor assembly into the lower right frame.

The screw holes on the motor assembly should match the screw holes in the lower right frame assembly.

N/A

7

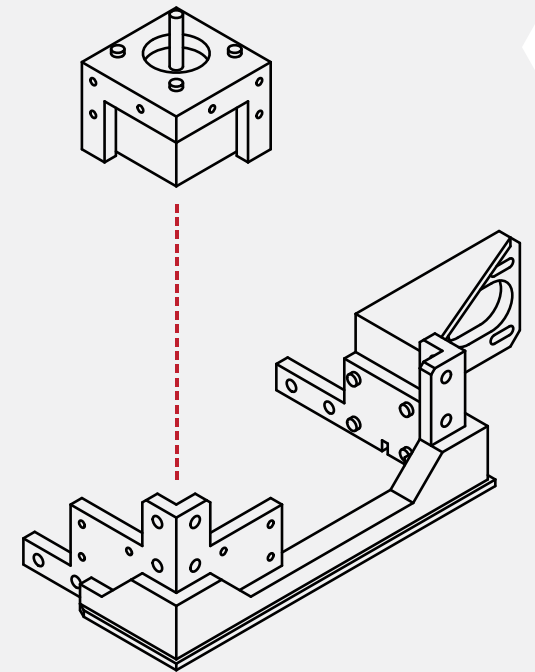

6

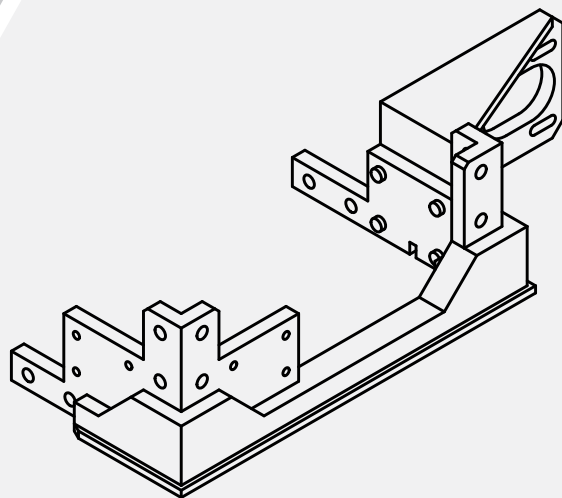

The Y axis motor mount is now complete.

Check the fitment of the mount to the lower frame.

Ensure that the mount is tight to the frame and secure.

Do not over-tighten the screws holding the mount in place.

N/A

From the hardware bag, collect **6 M3 X 10** screws.

Using your **M3 Hex wrench**, attach the motor assembly to the lower frame assembly.

X 6



8

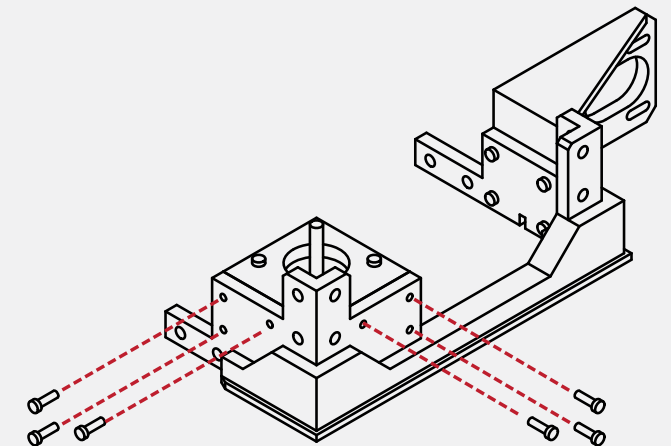

1

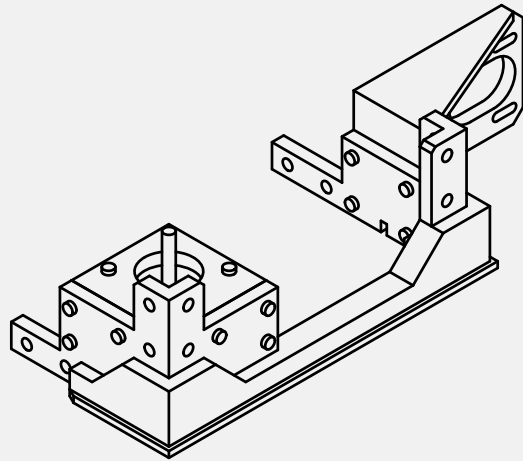

Congratulations, you've completed the right lower frame assembly.

Check the fit and ensure that all screws are tight.

Don't over tighten the screws, as this may strip the parts.

N/A

2

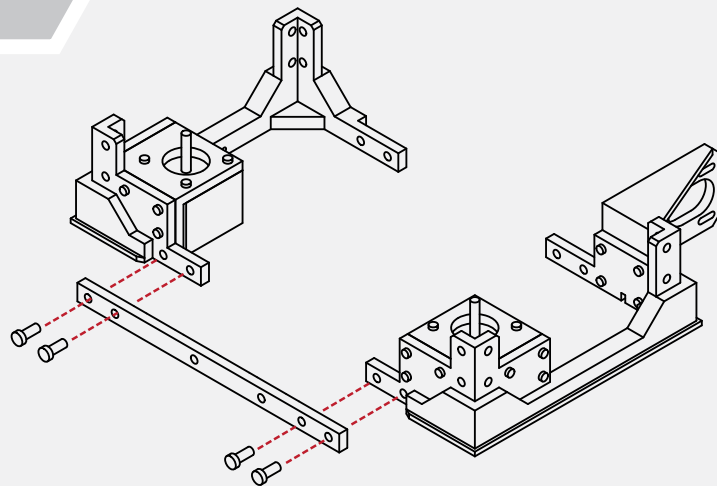

From the printed parts kit, locate the **front lower frame rail**. The front lower frame rail should be longer in length than the rear.

Take the **left and right lower frame assemblies** and match it to the lower front frame rail.

From the hardware bag select **4 M5 X 12** screws and using your **hex wrench** screw them through the lower front rail and into the left and right lower frame assemblies.

Check to make sure the pieces align and there are no gaps.

X 4



Similar to the previous step, select the **rear lower frame rail** from the parts kit. This rail is longer than the front lower rail.

Select **4 M5 X 12** screws from the hardware bag.

Like the previous step, take the screws and using your **hex wrench** attach the rear frame rail to the lower frame assemblies.

Ensure that the screws are tight and that there are no gaps or alignment issues with the pieces.

X 4



3

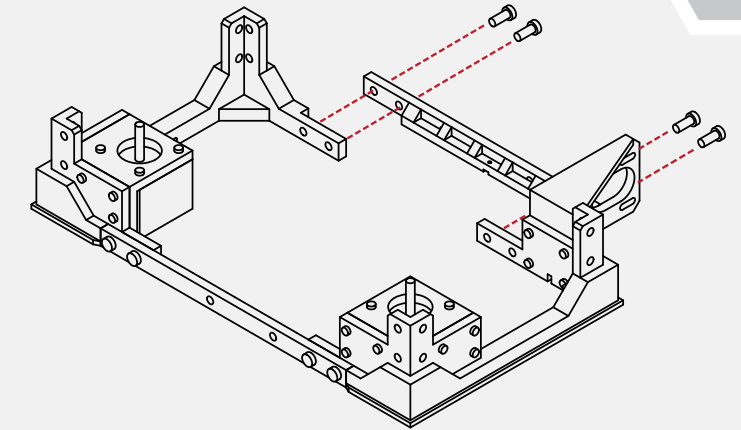

4

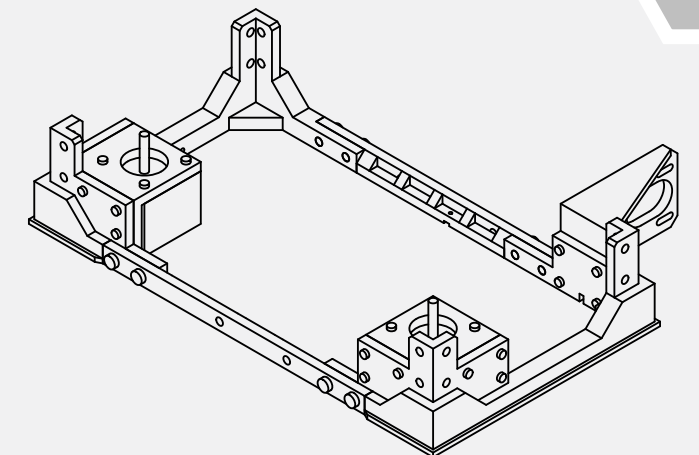

Congratulations! You've completed the lower frame assembly!

Take a break and marvel at your accomplishment.

N/A

1

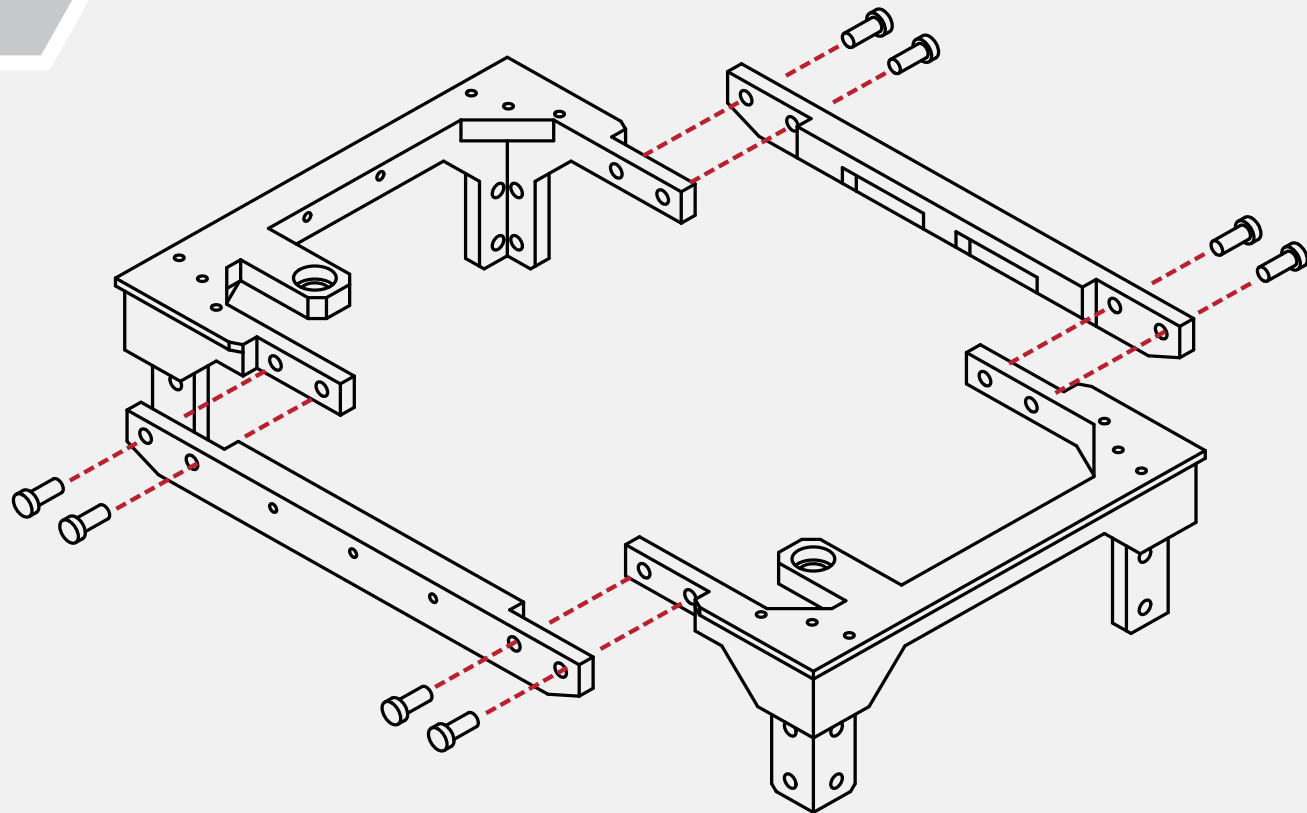

The upper frame assembly is similar to the lower frame assembly. You will need to locate the **left and right upper frame assemblies, as well as the front and rear upper frame rails**.

The front frame rail is easily identified by the 3 screw holes for the LCD panel. You will also need to collect **8 M5 X 12 screws** from the hardware bag.

Like the lower assembly, use your hex wrench to secure the upper frame rails to the upper frame assemblies.

X 8



M5 x 12

2

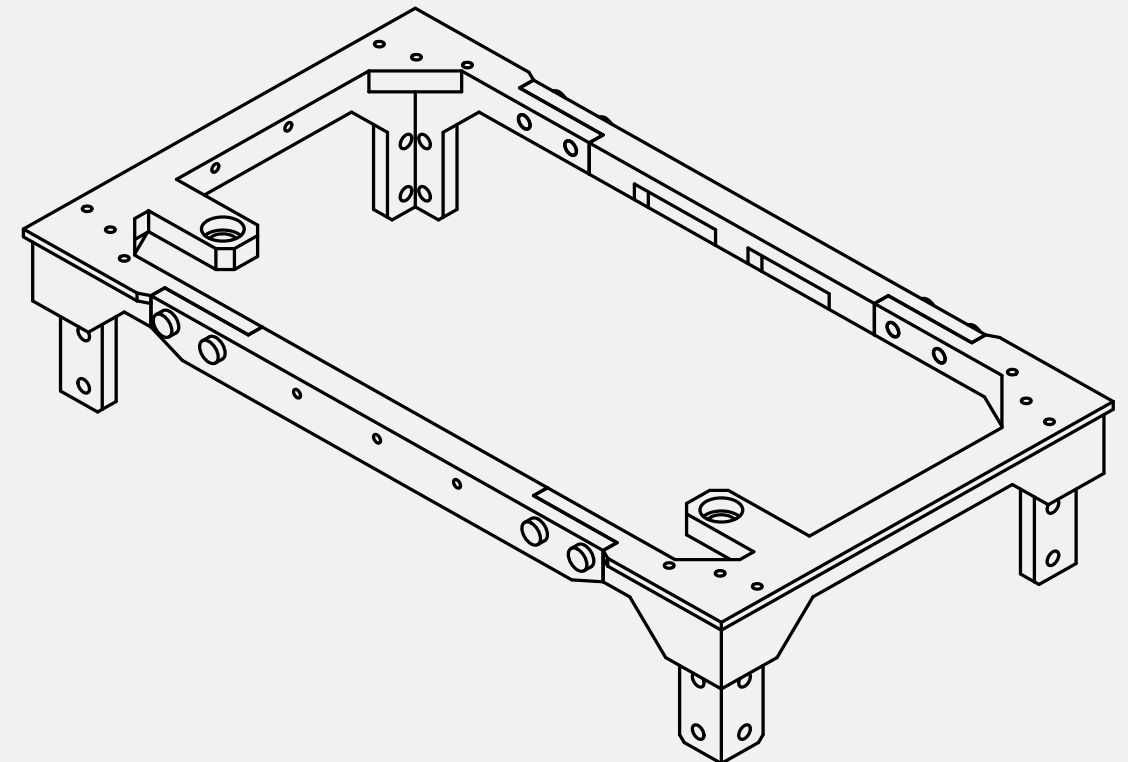

N/A

Congratulations! You've assembled the upper frame assembly! Wasn't that easy?

Take a moment to check that the frame appears square and that the frame rails are tight to the frame assemblies.

Ensure that the screws are not over-tightened as well.

1

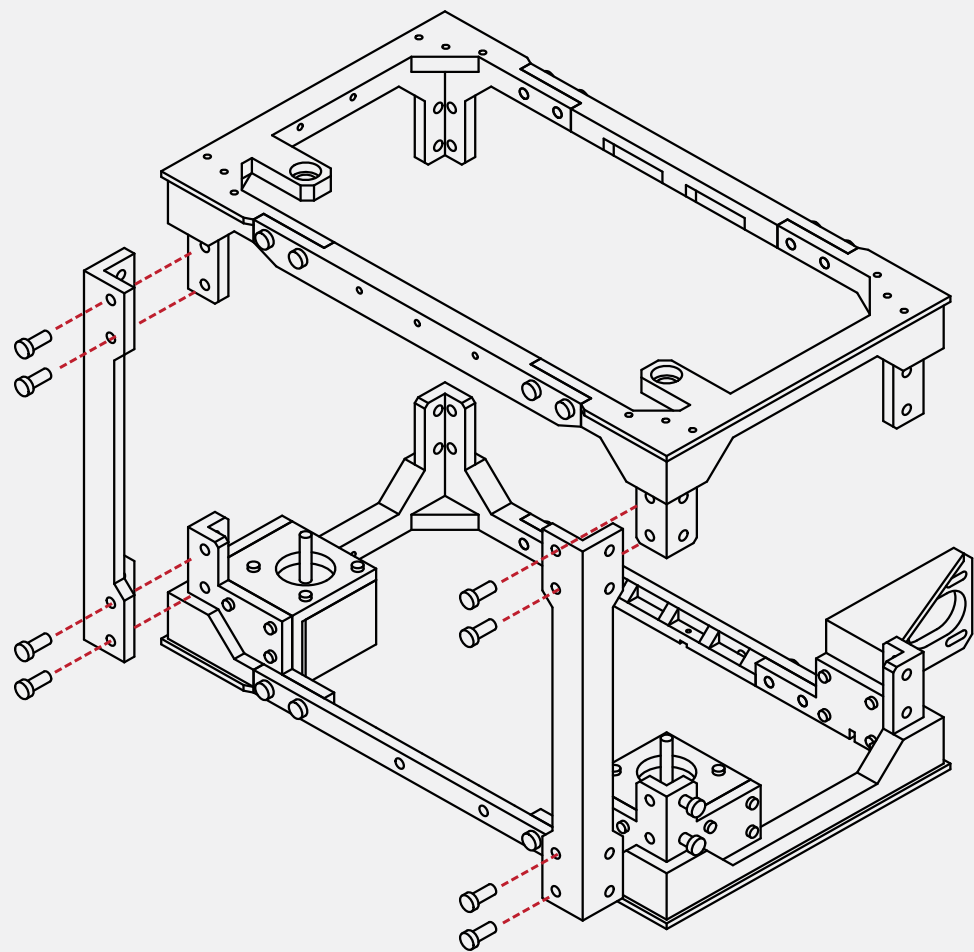

From the parts kit, select **2 of the main frame uprights**. These pieces are universal and can be fitted in any position.

Select **8 M5 X 12 screws** from your hardware bag as well.

Using your **hex wrench**, install the screws into the frame uprights, and then into the lower and upper frame assembly.

It is best to assemble the lower frame before the upper frame assembly.

X 8



M5 x 12

2

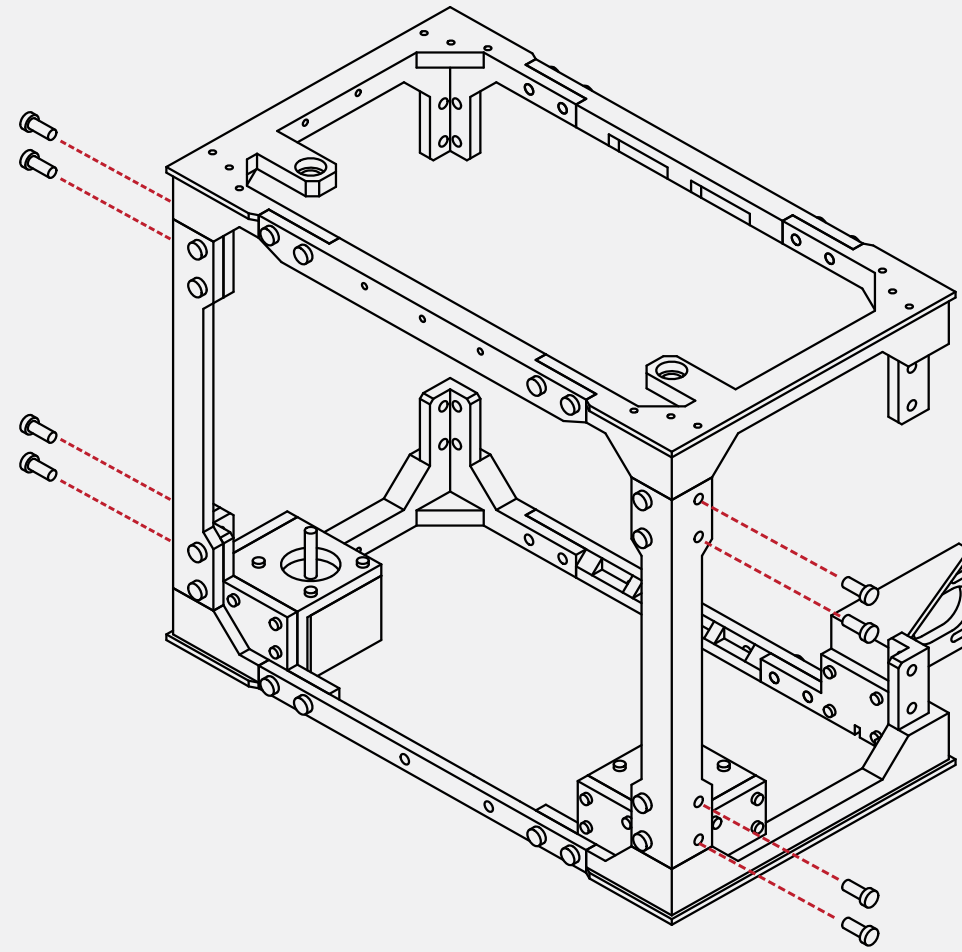

X 8



M5 x 12

With the first uprights installed, from your hardware bag, select **8 additional M5 X 12 screws**.

Using your **hex wrench**, install the screws into the uprights.

Ensure that the uprights are tight and aligned to the upper and lower frame assemblies.

3

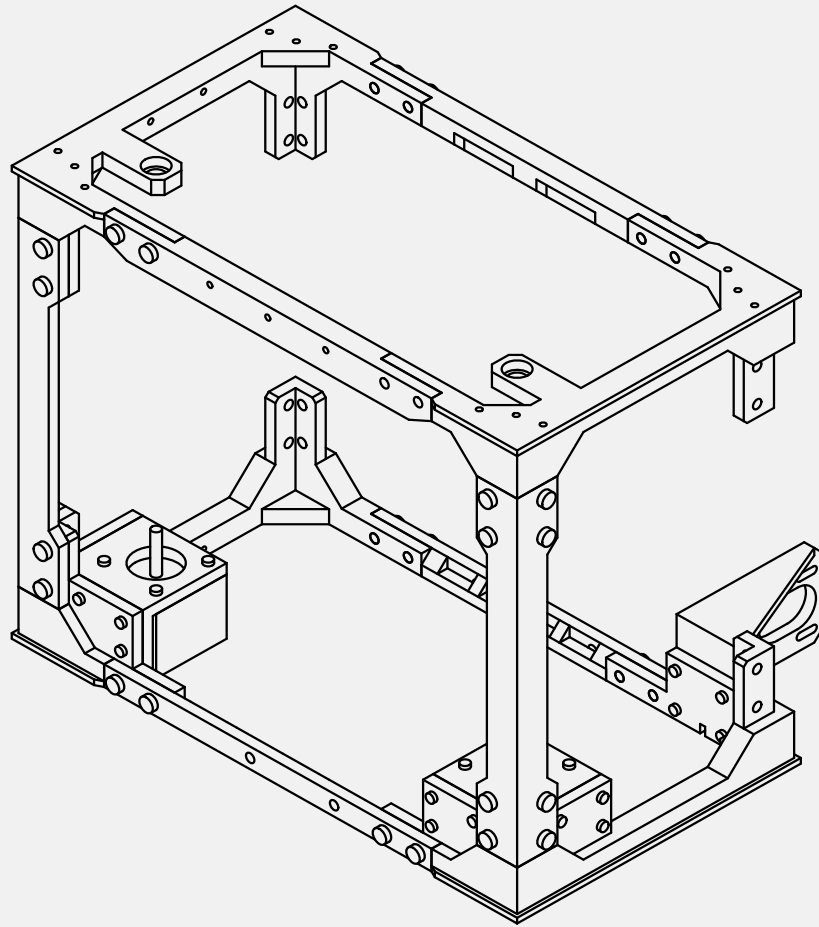

Congratulations! You've installed half of the frame!

We're almost done!

N/A

4

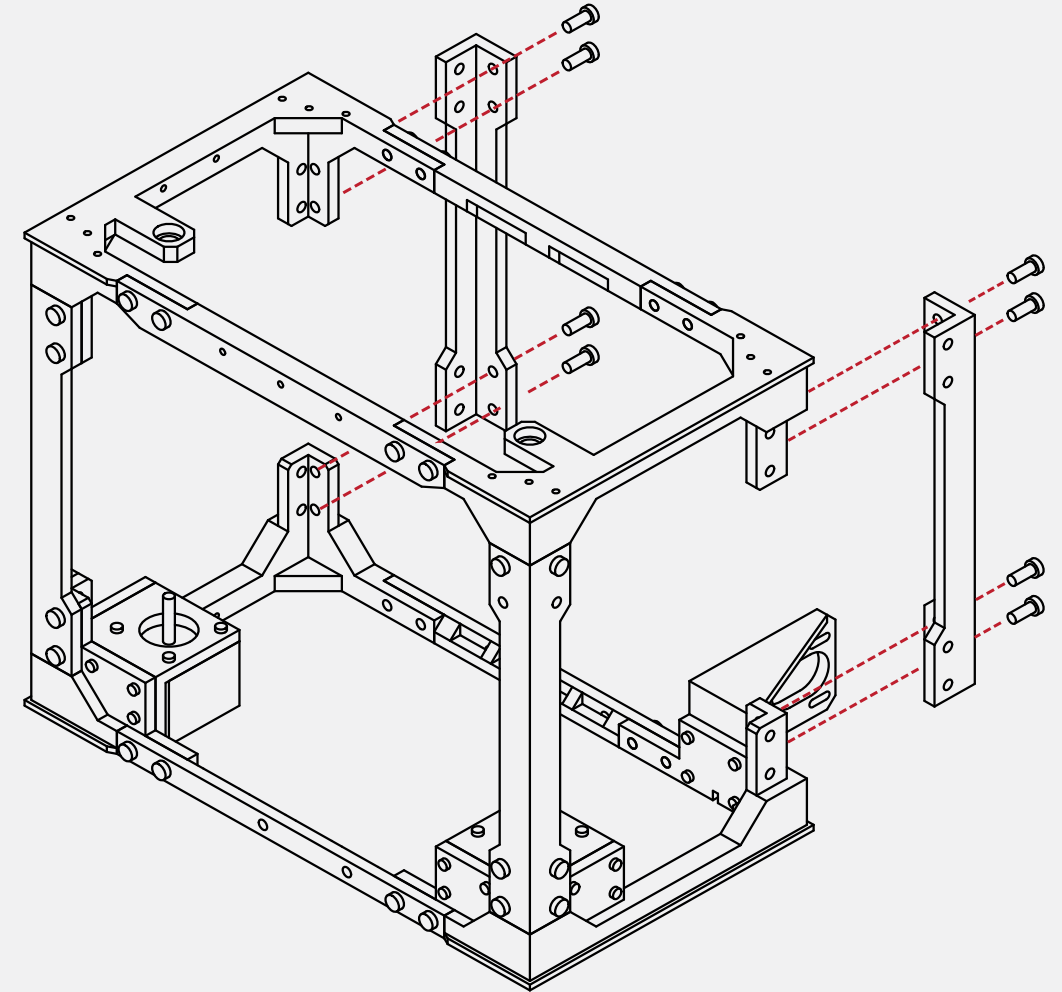

X 8

 M5 x 12

Like our previous step, select the **two remaining frame uprights** and check their fitment to the rest of the frame assembly.

Select **8 M5 X 12** screws from the hardware bag.

Using your **hex wrench**, attach the two uprights to the rear of the frame.

5

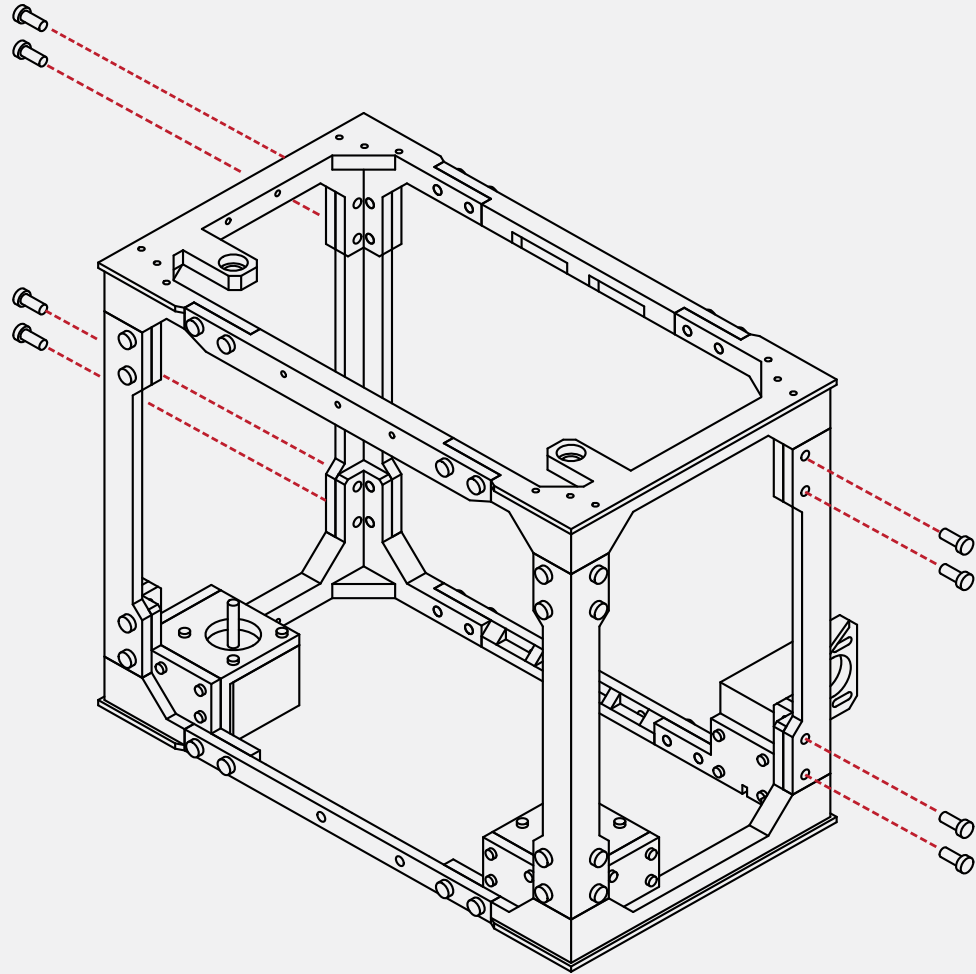

Select **8 additional M5 X12** screws from your hardware bag.

Using your **hex wrench**, install the remaining screws into the uprights and frame assemblies.

X 8



6

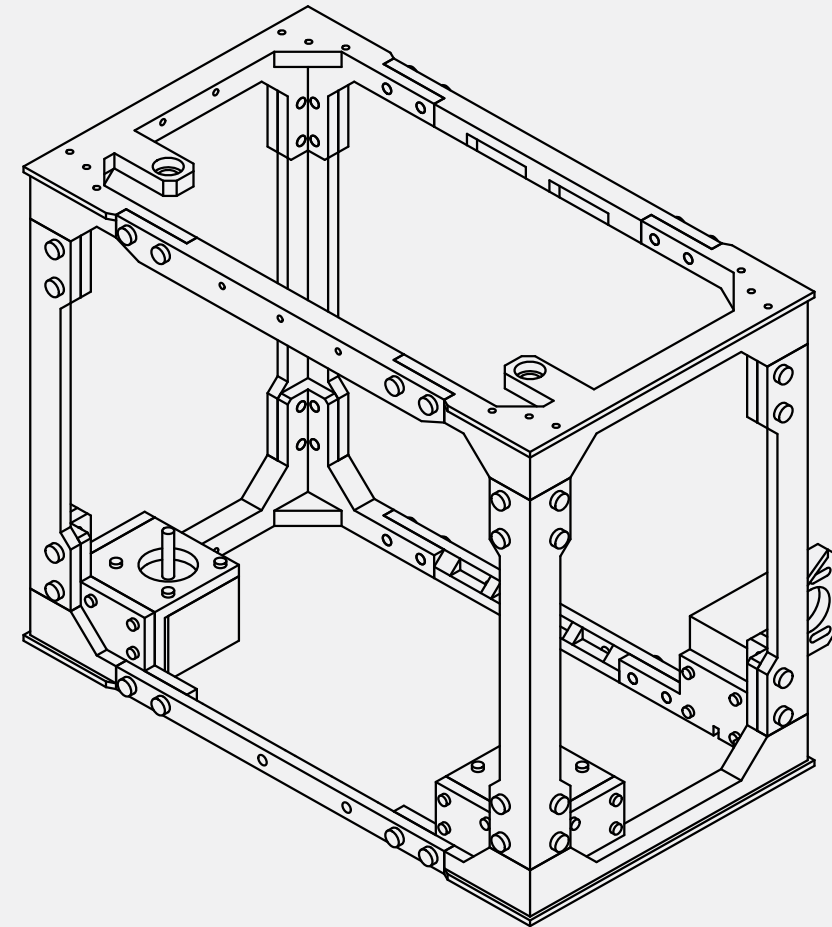

N/A

Congratulations! You've completed the outside frame!

This frame makes up the structural elements of your printer, and is the building block for the remaining elements!

You've done an awesome job, and I'm sure it looks amazing!

Take a moment to relax and marvel at your feat of engineering, we're going to be kicking it up a notch in the next chapter!

SECTION

C

3.1 Extruder Assembly

34

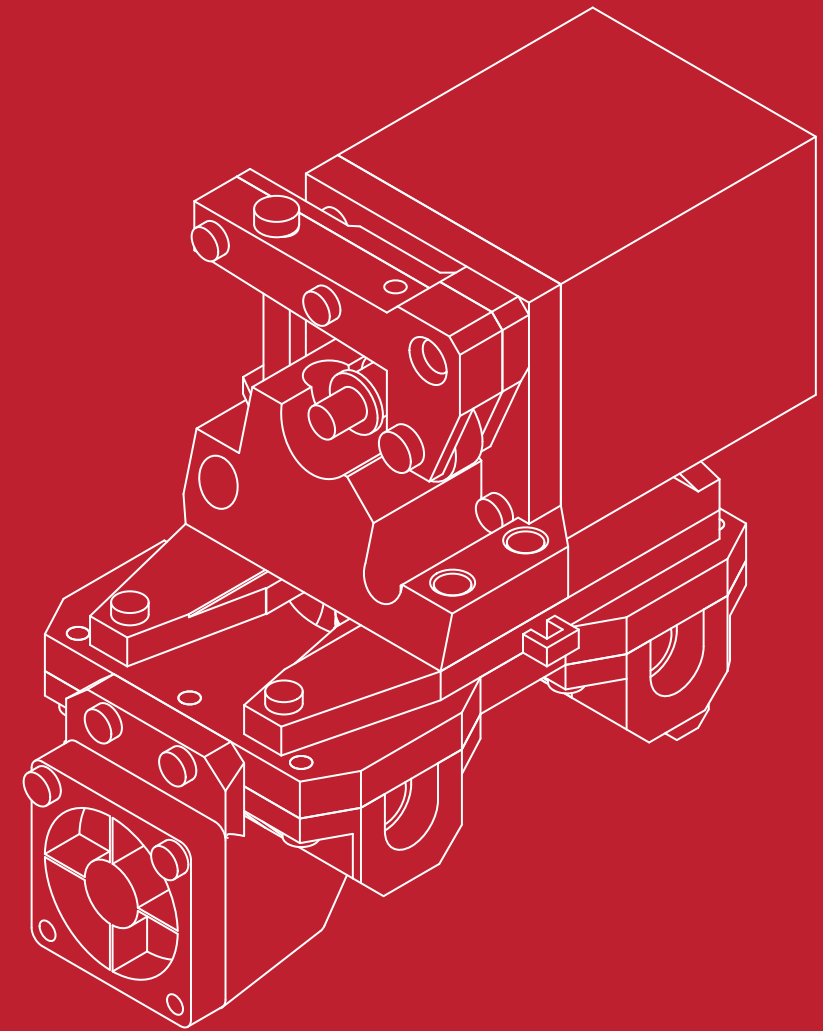

1

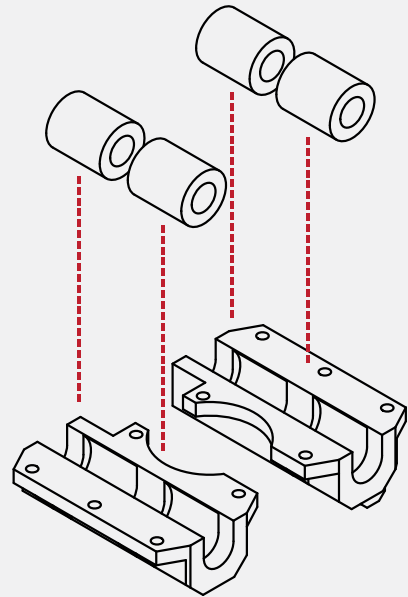

From the hardware kit, locate **4 LMS8UU linear bearings**, and the **2 lower extruder bearing carriers**. These can be identified by their semi circle cut outs.

Insert the bearings into the bearing carriers. Take care not to damage the bearings as they are inserted.

N/A

2

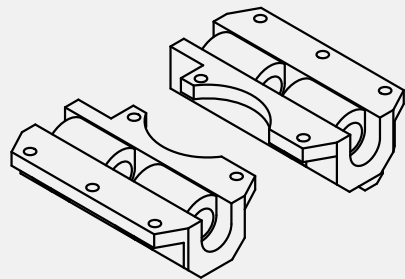

When fully inserted, the bearings should protrude slightly from the carriers.

Ensure that the bearings are aligned, and fully seated before proceeding to the next step.

N/A

3

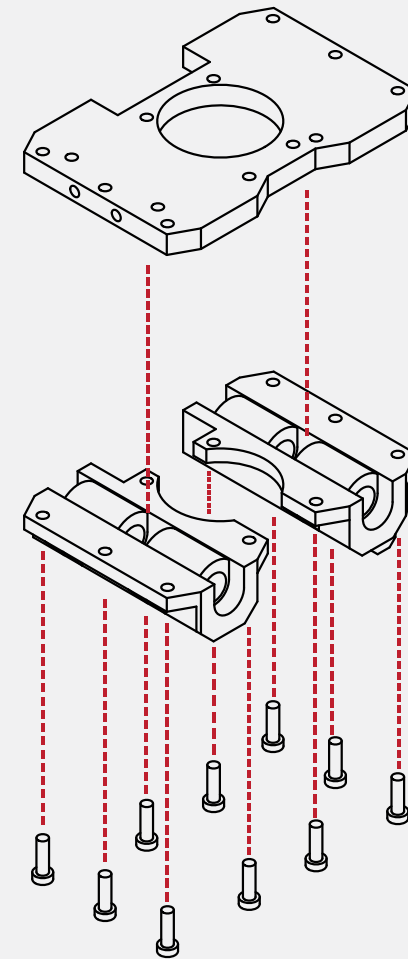

X 10



Locate the **lower extruder base** from the hardware kits.

From the hardware bag, select **10 M3 X 10** screws.

Align the lower bearing carriers with the extruder base. The semi circle cut-outs should align with the opening in the extruder base.

Using your **hex wrench**, install 5 of the screws into each of the bearing carriers, and into the extruder base.

4

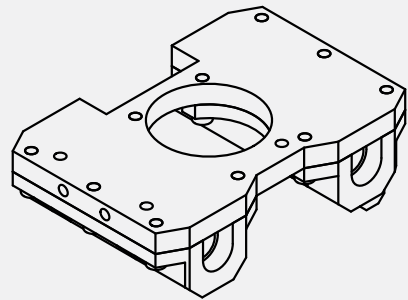

With the carriers mounted to the extruder base, check that the parts fit well and that there are no loose screws.

The bearings should be solidly captured and should not rattle or move once the pieces are assembled.

N/A

Check that there is not any excessive play in the mount.

If there is any play in the mount, use a small piece of tape on the mount to shim the hot-end.

If the play is excessive, contact us for a replacement or solution.

N/A

6

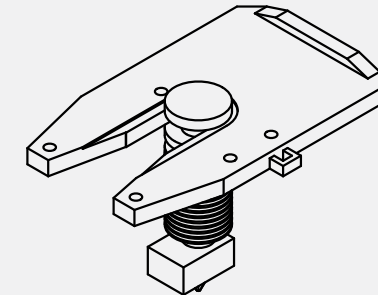

5

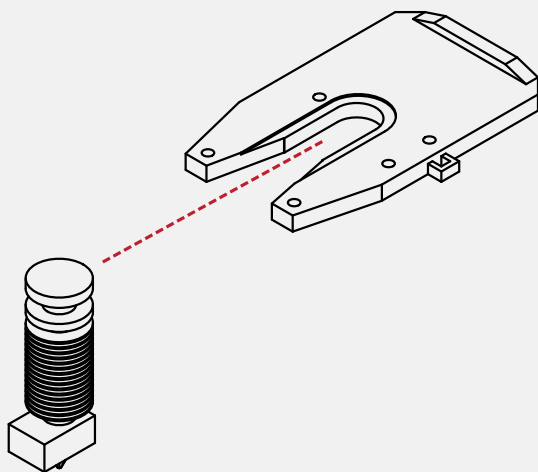

Locate your **hot-end** from the parts kit. We will be wiring and installing the remainder of its components later in this build.

Locate the **hot-end mounting plate** from your hardware kit as well.

Insert the hot-end into the mount.

The flange on the hot-end should seat snugly up against the lower mount.

N/A

Select **2 M3 X 10** screws from your hardware set.

Install the screws into the hot-end mount, and into the extruder base.

Ensure that the mount is securely attached to the lower frame assembly.

X 2

 M3 x 10

7

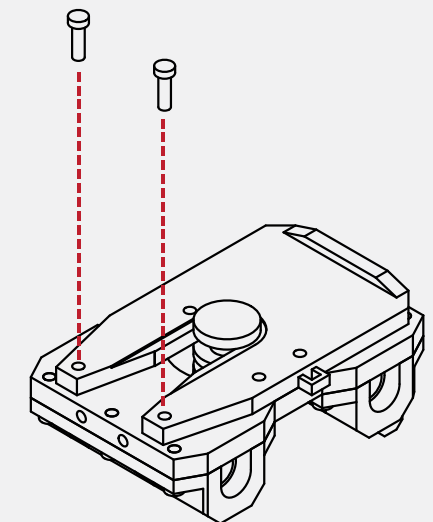

8

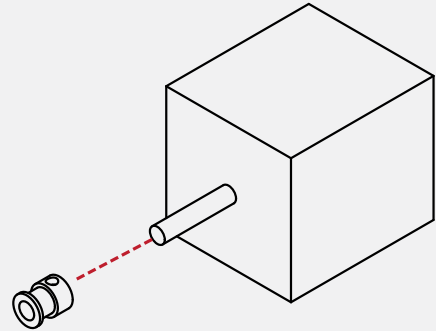

From the hardware kit, select one of the remaining **48mm stepper motors**, as well as the **MK8 extruder gear** and the included **grub screw**.

N/A

9

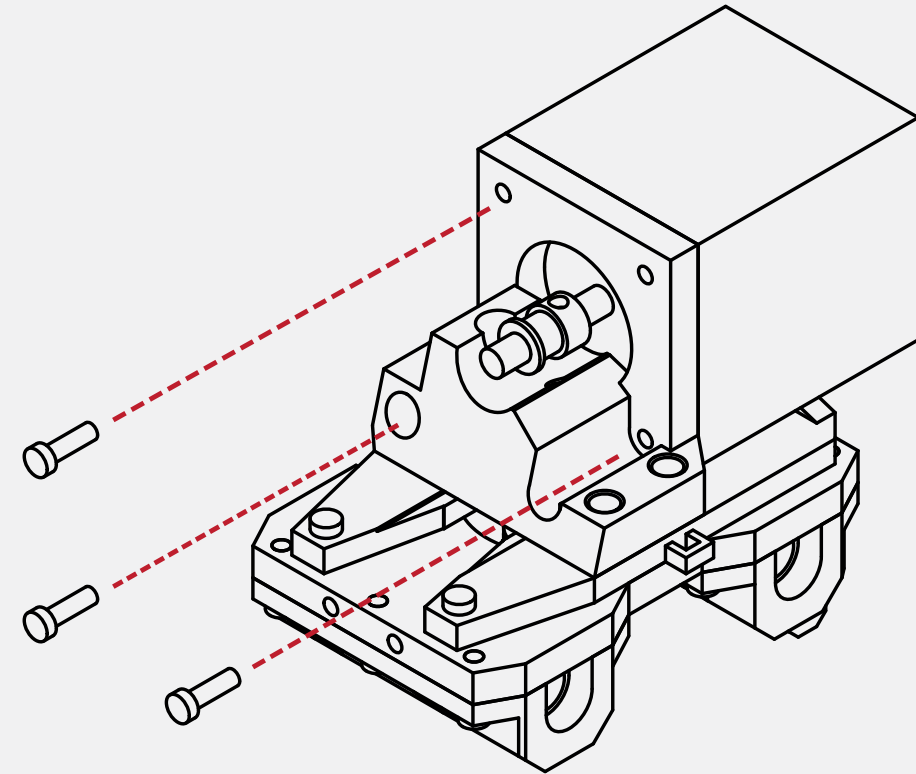

X 3

 M3 x 10

Locate the **upper extruder mount** from the hardware kit, and **3 M3 X 10 screws**.

Insert the stepper motor into the extruder mount.

Take note to orientate the position of the motor such that the wire connectors are facing upwards.

Insert the 3 M3 X 10 screws through the extruder mount and into the stepper motor.

9

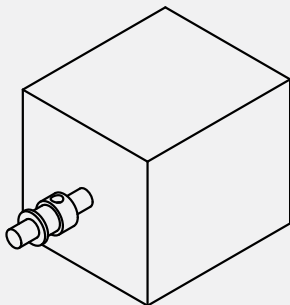

Place the extruder drive gear onto the shaft of the stepper motor.

Use the **small hex wrench** to slightly tighten the grub screw to hold the gear in place.

We will need to fine-tune the gear's location later in this guide, so do not tighten the screw completely.

N/A

10

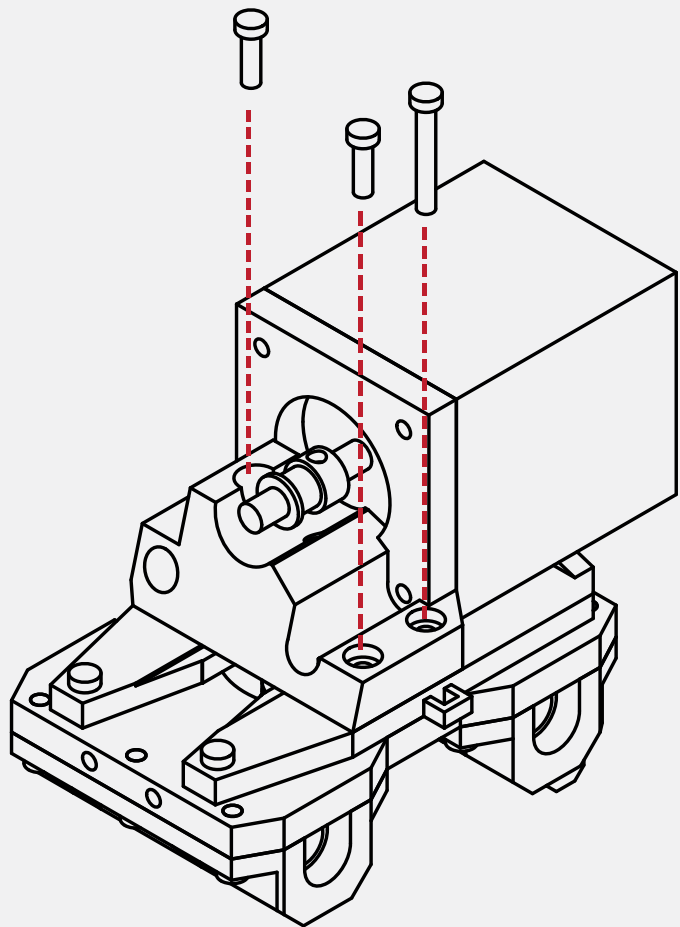

Locate **2 M3 X 10 screws** and **1 M3 X 20 screws**.

Take the **lower extruder assembly** and the **upper extruder assembly** from the previous steps and mate them together. The screw holes should align.

Insert the **M3 X 20** screw into the right-rear hole, and the 2 remaining screws into the other openings.

Check that the screws are tight, and that the mount is secure. The hot-end should also be firmly in place with no slop or play.

- X 2  M3 x 10
- X 1  M3 x 20

11

Locate both the **front and rear extruder arm components**, as well as **2 M3 X 10, and 1 M3 X 20 screws**.

Place the two arm components face to face. The screw holes should align.

Insert the M3 X 10 screws into the arms to secure them together. Place the M3 X 20 screw into the last opening.

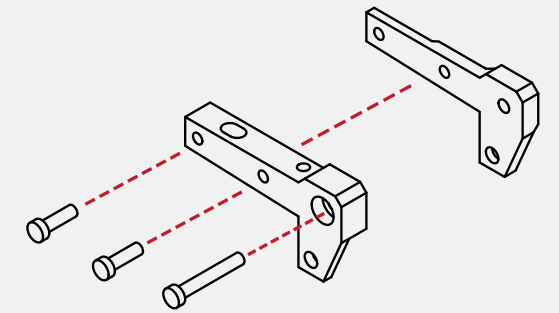

- X 2  M3 x 10
- X 1  M3 x 20

12

The extruder arm is almost complete. Check that all the screws are tight and that the parts fit correctly.

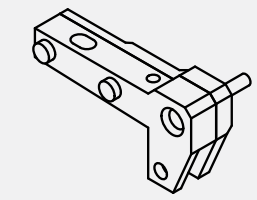

N/A

13

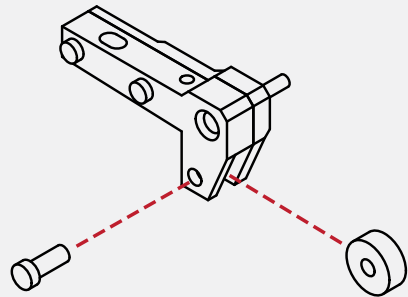

Locate **1 radial ball bearing** and **1 M4 X 10 screw** from the hardware kit.

Insert the bearing into the opening of the extruder arm, and using your **hex wrench** install the screw into the arm, and through the bearing.

When tight, the bearing should still rotate freely.

X 1



14

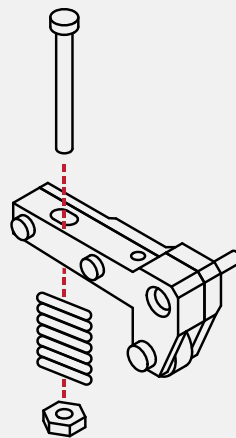

Locate **1 M4 X 40 screw**, **1 compression spring**, **2 washers**, and **one M4 nut**.

Place the screw through the extruder arm, afterwards place one washer, the compression spring, a second washer, and finally the nut onto the screw.

Thread the nut partially compress the spring.

X 1



15

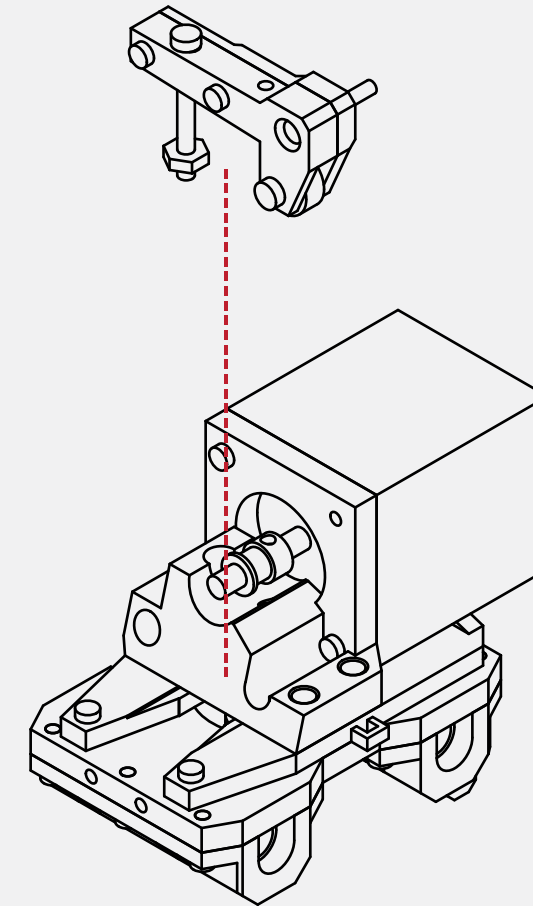

N/A

Using the extruder assembly from the previous step, take the completed extruder arm and place it onto the extruder assembly.

The longer screw on the extruder arm should slot into the base of the extruder. The flat faces of the nut should also match the side of the extruder base as well.

16

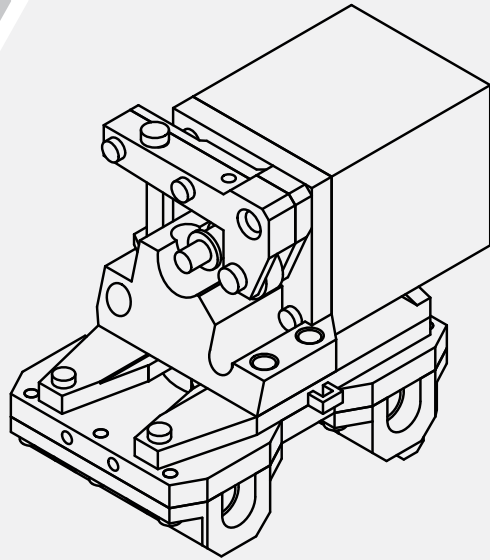

Insert a washer between the extruder arm and extruder assembly.

Screw the last M3 X 20 screw from the extruder arm into the extruder assembly and stepper motor.

The arm should move freely. By tightening or loosening the extruder spring screw, you can adjust the tension between the extruder gear and idler bearing. For now, set the tension so that the idler bearing is pressing against the extruder gear.

N/A

17

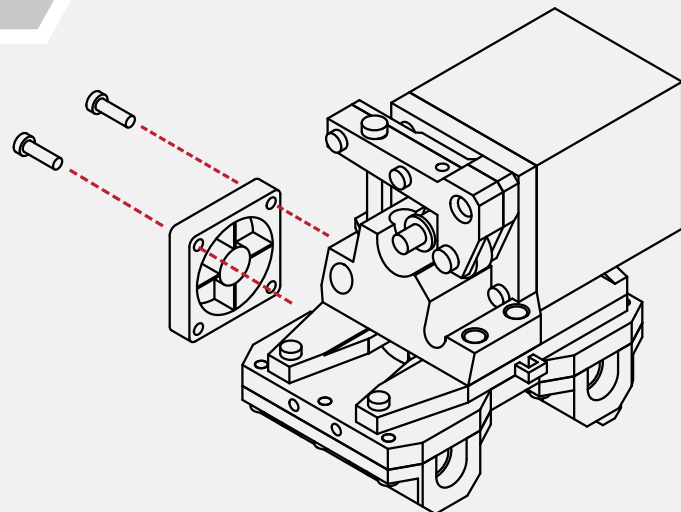

Select one of the **30mm cooling fans** from your parts kit, and **2 M3 X 16 screws**.

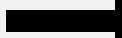

Using your **hex wrench**, attach the cooling fan to the side of the extruder assembly.

The cooling fan should sit flush with the extruder assembly.

X 2  M3 x 16

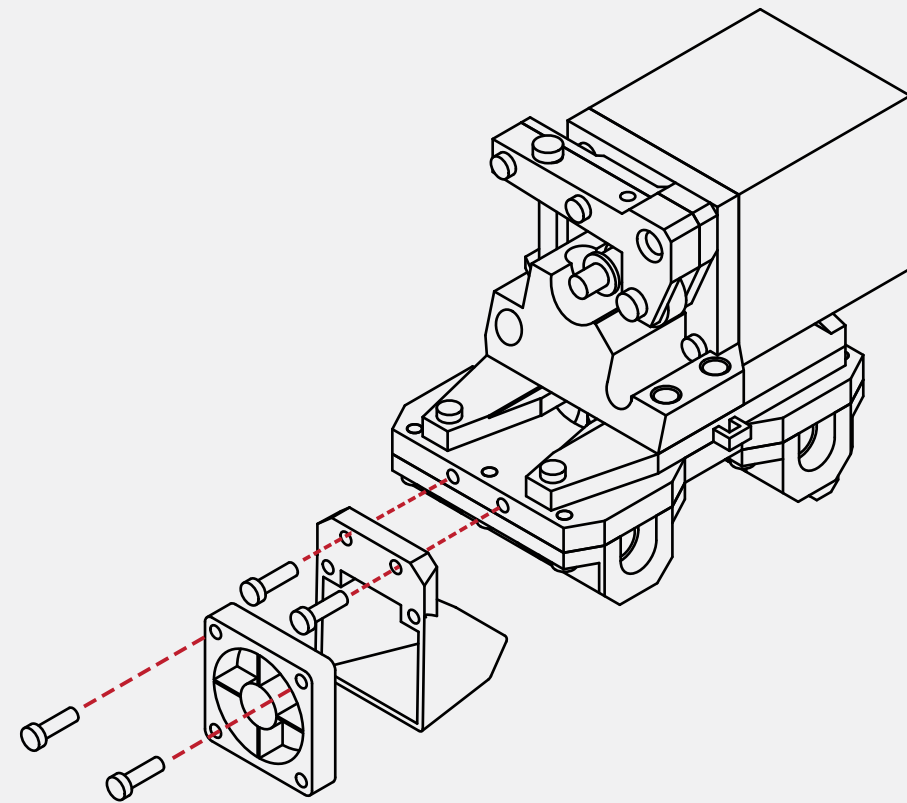
18



X 2  M3 x 16
X 2  M3 x 10

Select one of the **30mm cooling fans**, and the **fan duct** from your parts kit.

Select **2 M3 X 16** and **2 M3 X 10 screws** from your hardware kit as well.

Attach the cooling fan to the fan duct using the M3 X 16 screws, and attach the fan duct to the extruder assembly using the M3 X 10 screws.

SECTION

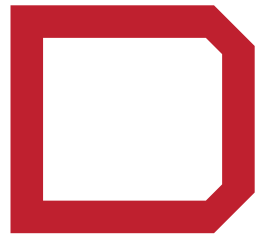

<i>4.1 X Carriage Assembly</i>	<i>48</i>
<i>4.2 Y Carriage Assembly</i>	<i>62</i>
<i>4.3 Print Bed Installation</i>	<i>76</i>
<i>4.4 Z Carriage Assembly</i>	<i>82</i>

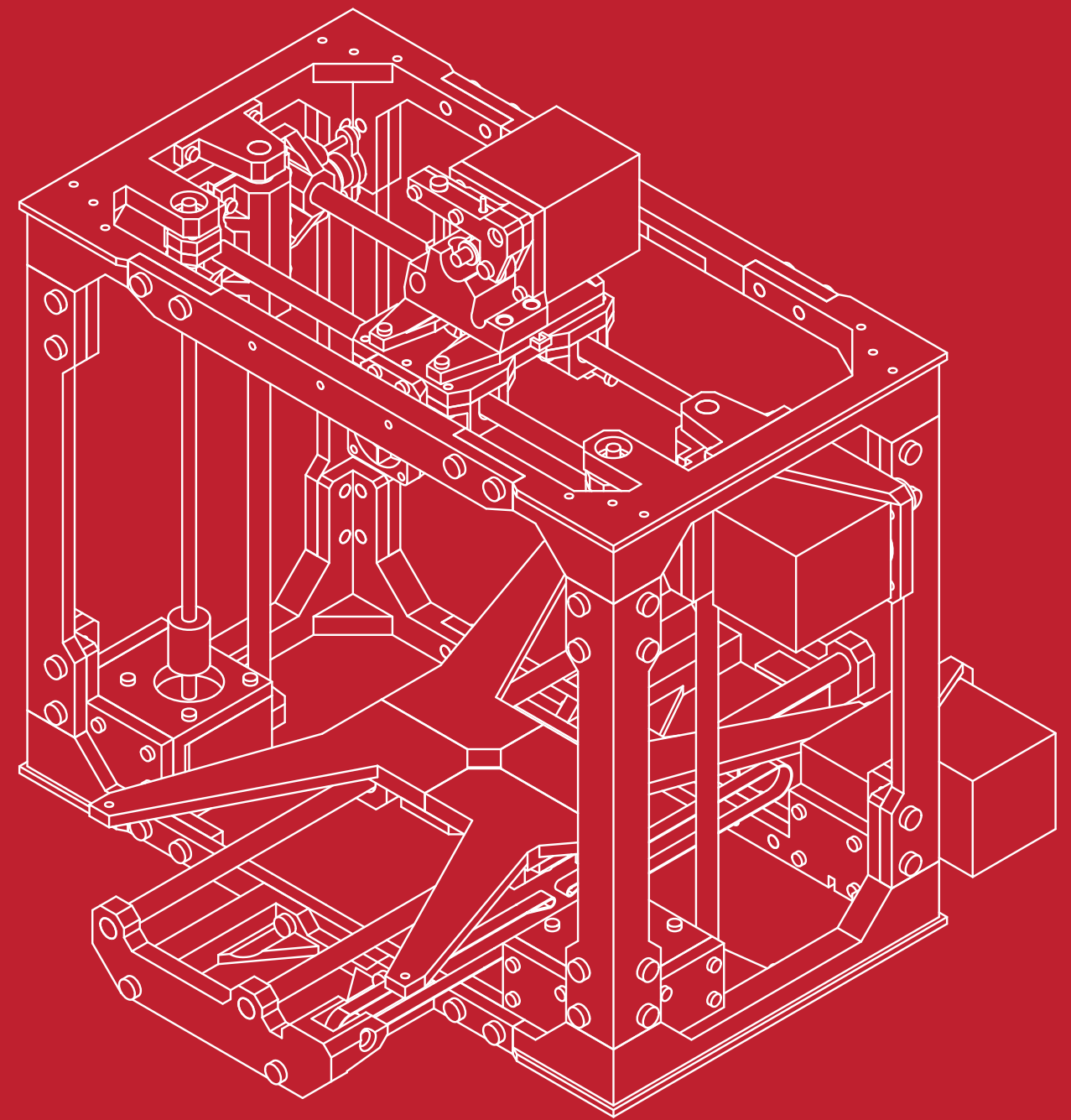

X Carriage Assembly

1

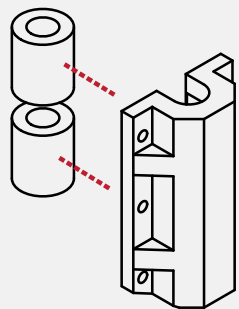

Locate the **Z Axis bearing holders** from your parts kit, and **2 linear bearings** from the hardware kits.

The Z axis bearing holders are identified by their 6 screw holes and slight chamfer on the leading edge.

Press the linear bearings into the bearing carrier and ensure that they are fully seated and aligned.

N/A

2

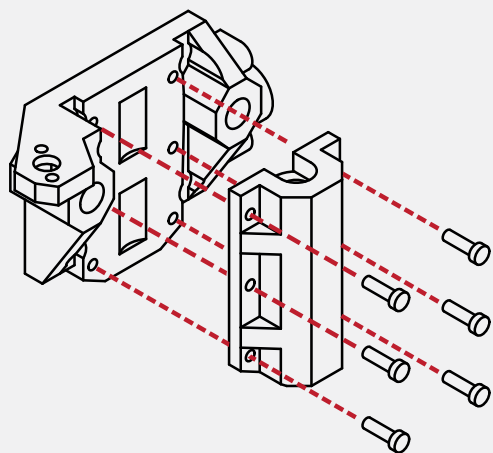

From your parts kit, locate the **left X axis mount**. The left X axis mount is identifiable by its semi-circle idler mounts on the rear.

Press the bearings and bearing holders into the X axis mount.

Ensure that the bearings and bearing carrier are flush with the mount and insert the **6 M3 X 10 screws** to secure the bearing and holder in place.

X 6



The left X axis mount is now complete.

Check that the bearing holder is tight to the X axis mount.

N/A

3

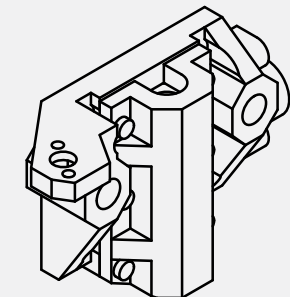

4

Locate one of the **M4 nuts** from the hardware kit along with **2 M3 X 10 screws**, along with the **Z axis capture plate**.

Insert the nut into the X axis carriage.

Using your **hex wrench**, insert the screws into the capture plate, and then attach the plate to the X axis assembly.

Take care not to damage the X axis mount or over tighten the screws.

X 2

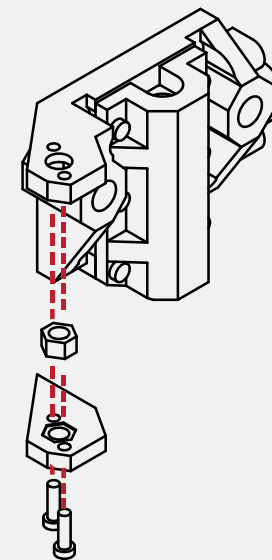

5

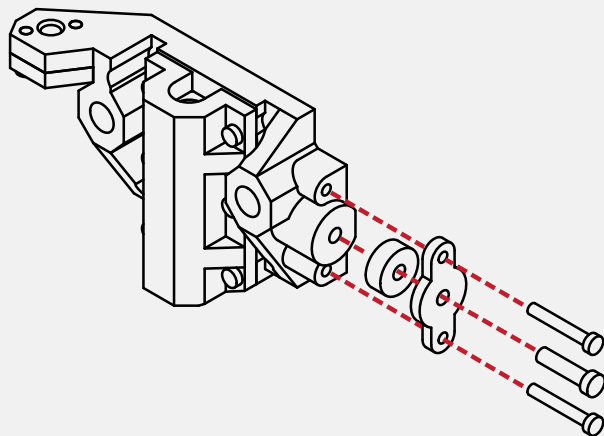

Take the completed **X axis assembly** and locate the **idler bearing cover plate**, along with **1 idler bearing**, **1 M4 X 16** and **2 M3 X 20 screws**.

Insert the screws through the cover plate, and place the idler bearing onto the M4 screw.

Using your **hex wrench**, screw the assembly into the X axis assembly.

- X 2  M3 x 20
- X 1  M4 x 16

Locate the **Z Axis bearing holders** from your parts kit, and **2 linear bearings** from the hardware kits.

The Z axis bearing holders are identified by their 6 screw holes and slight chamfer on the leading edge.

Press the linear bearings into the bearing carrier and ensure that they are fully seated and aligned.

N/A

7

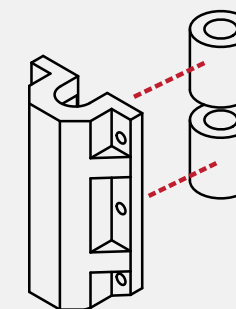

6

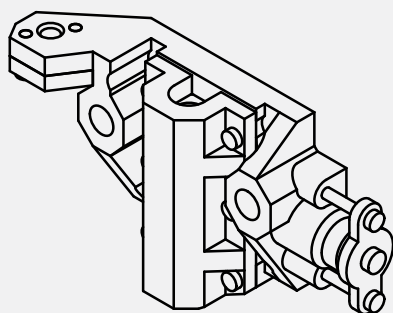

The left X assembly is now complete. Check that the idler bearing spins freely, and that all screws are tight and secure.

N/A

8

From your parts kit, locate the **right X axis mount**. Ensure that the bearings and bearing carrier are flush with the mount and insert the **6 M3 X 10 screws** to secure the bearing and holder in place.

Locate one of the **M4 nuts** from the hardware kit along with **2 M3 X 10** screws, along with the **Z axis capture plate**.

Insert the nut into the X axis carriage.

Using your **hex wrench**, insert the screws into the capture plate, and then attach the plate to the X axis assembly.

- X 6  M3 x 10

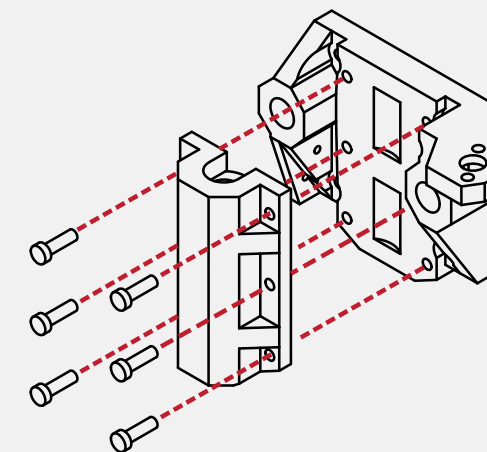

9

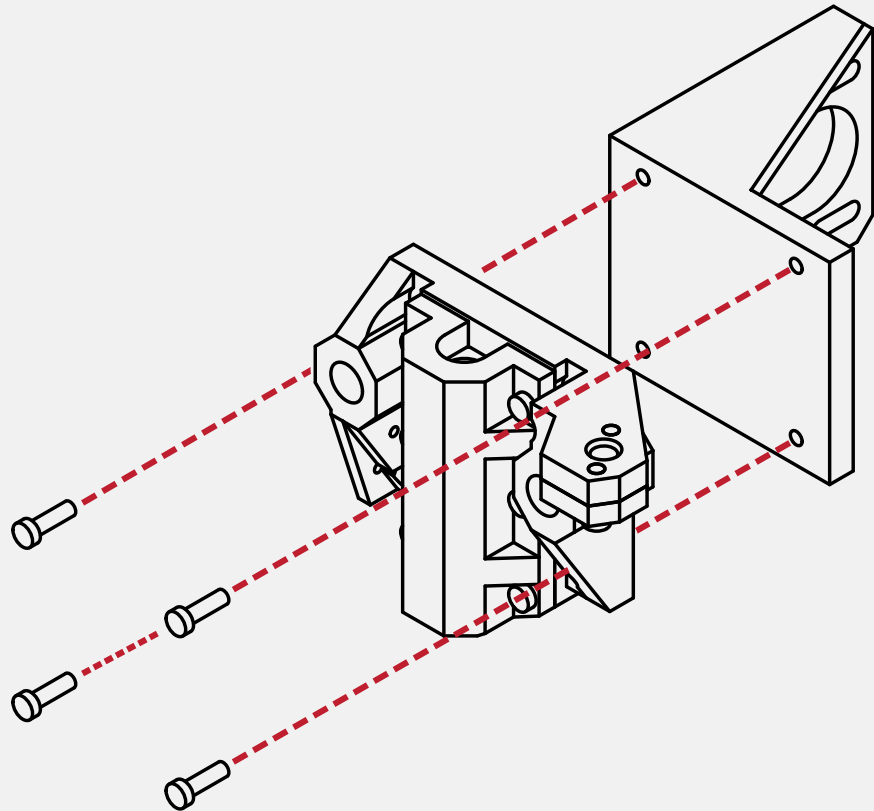

Locate the **X axis motor mount, and right X axis mount**. From your hardware kit, select **4 M3 X 10 screws**.

X 4



Align the X axis mount with the motor mount, and using your **hex wrench** install the 4 screws.

Ensure that the motor mount is flush and tight with the X axis mount.

From the hardware kit, select one of the remaining **48mm stepper motors**, as well as the **GT2 Pulley**.

N/A

10

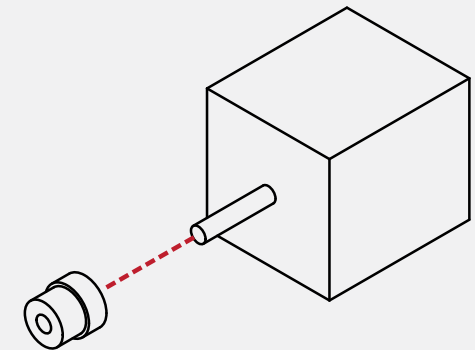

Place the **GT2 Pulley** onto the shaft of the stepper motor.

Use the **small hex wrench** to slightly tighten the grub screw to hold the gear in place.

We will need to fine-tune the pulley's location later in this guide, so do not tighten the screw completely.

N/A

11

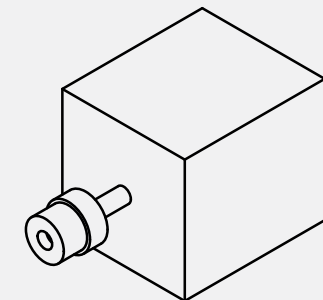

12

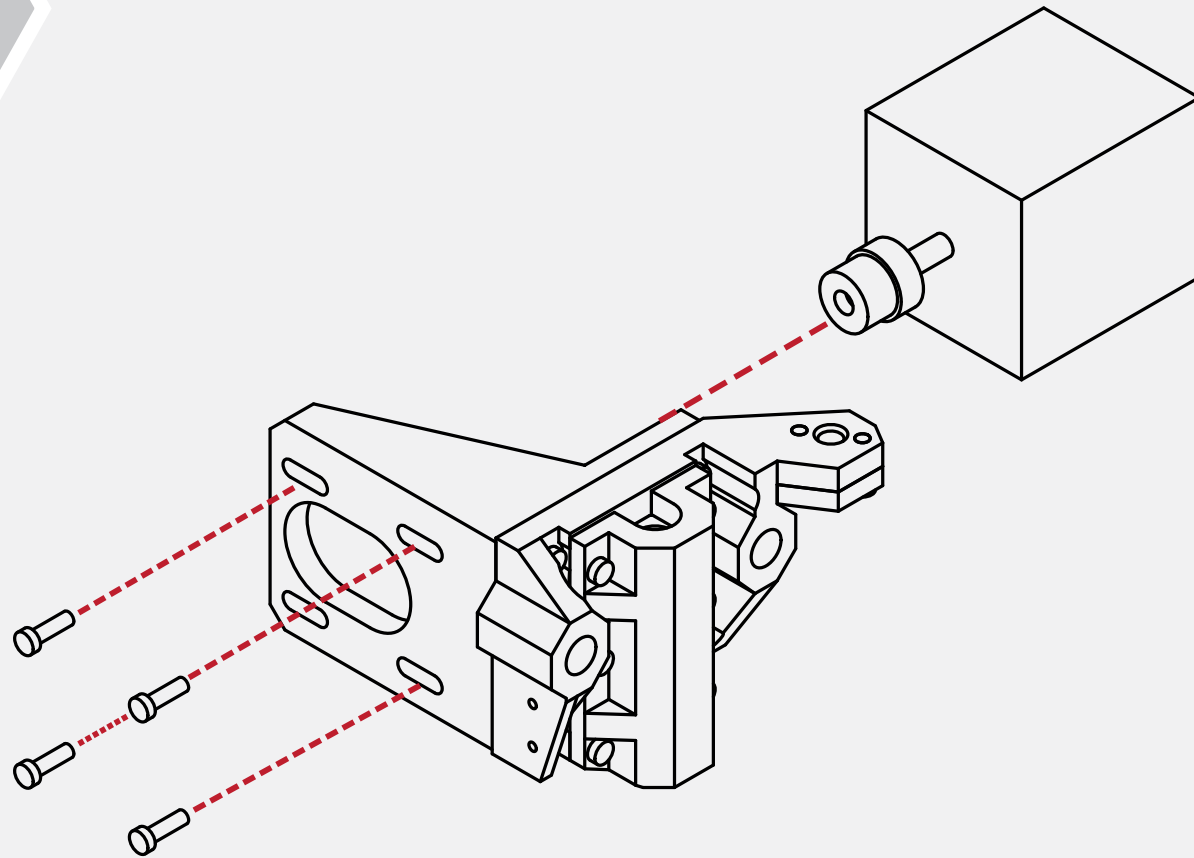

From your hardware kit, locate **4 M3 X 10 screws**, and gather the **stepper motor and X axis assembly** from the previous steps.

Insert the stepper motor into the motor mount. Ensure that the cable connector on the motor is facing upwards.

Using your **hex wrench**, insert the 4 M3 X 10 screws into the motor mount and into the stepper motor. We will be adjusting the motor tension later in this guide, so there is no need to completely tighten the screws.

X 4



13

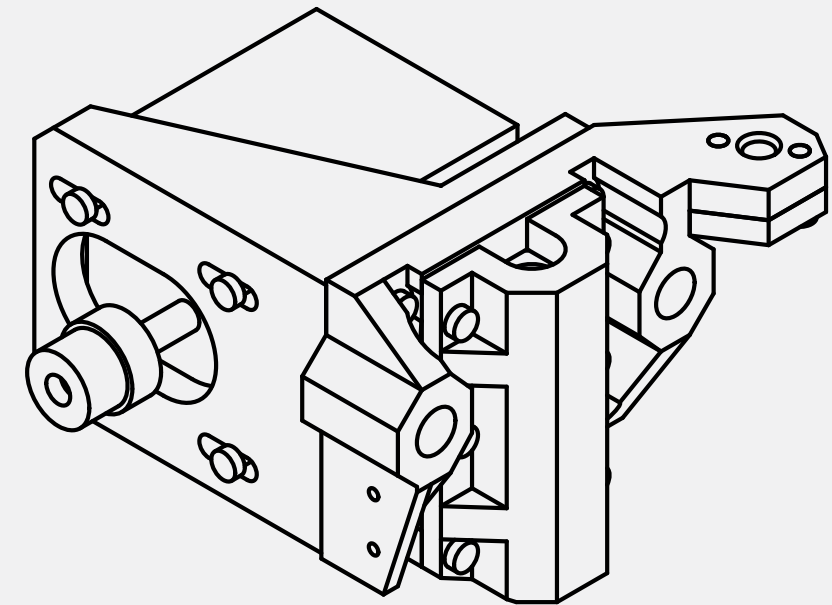

N/A

Congratulations! You've completed the X motor assembly.

Take a moment to ensure that all the screws and parts fit correctly and are tight.

14

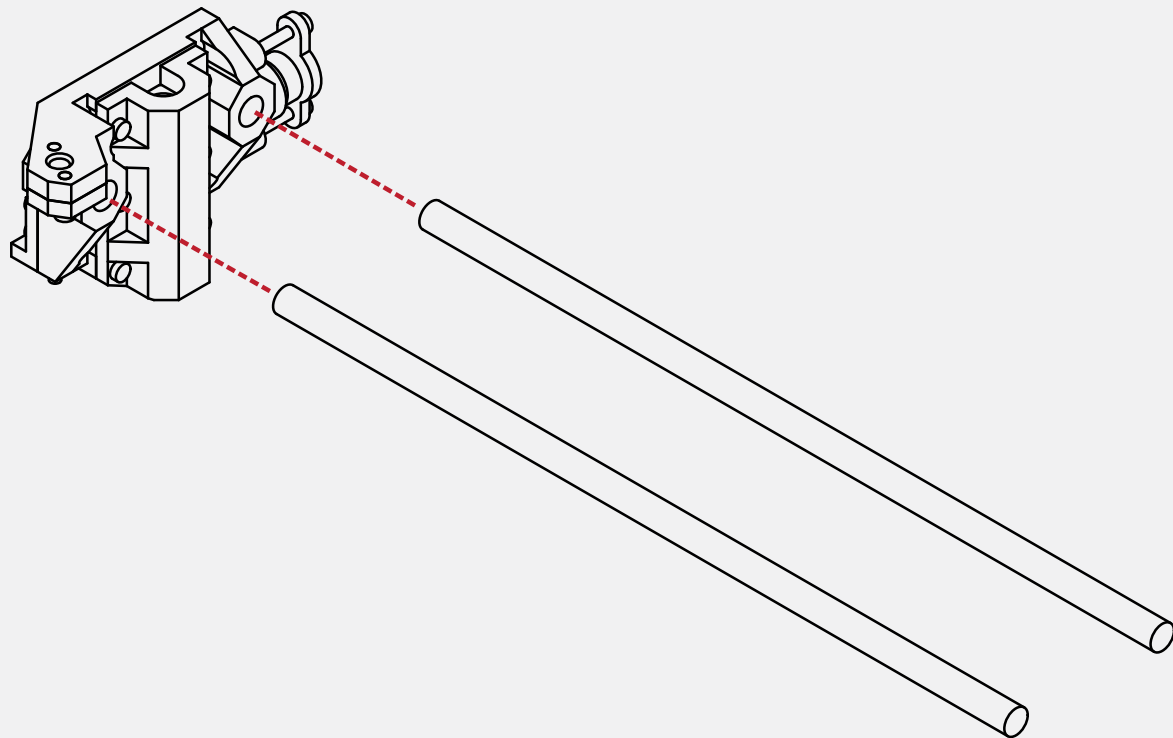

Locate the left **X assembly** from the previous steps as well as **2 250mm linear rod**.

N/A

These rods are the same length as the rods used for the Z axis, but shorter than those used for the Y axis. Using a soft mallet, gently drive the rods into the X assembly.

Take care to ensure the rods are inserted square to the assembly and that you do not damage the X axis assembly. When fully inserted, the rods should rest against the small openings on the backside of the X axis assembly.

15

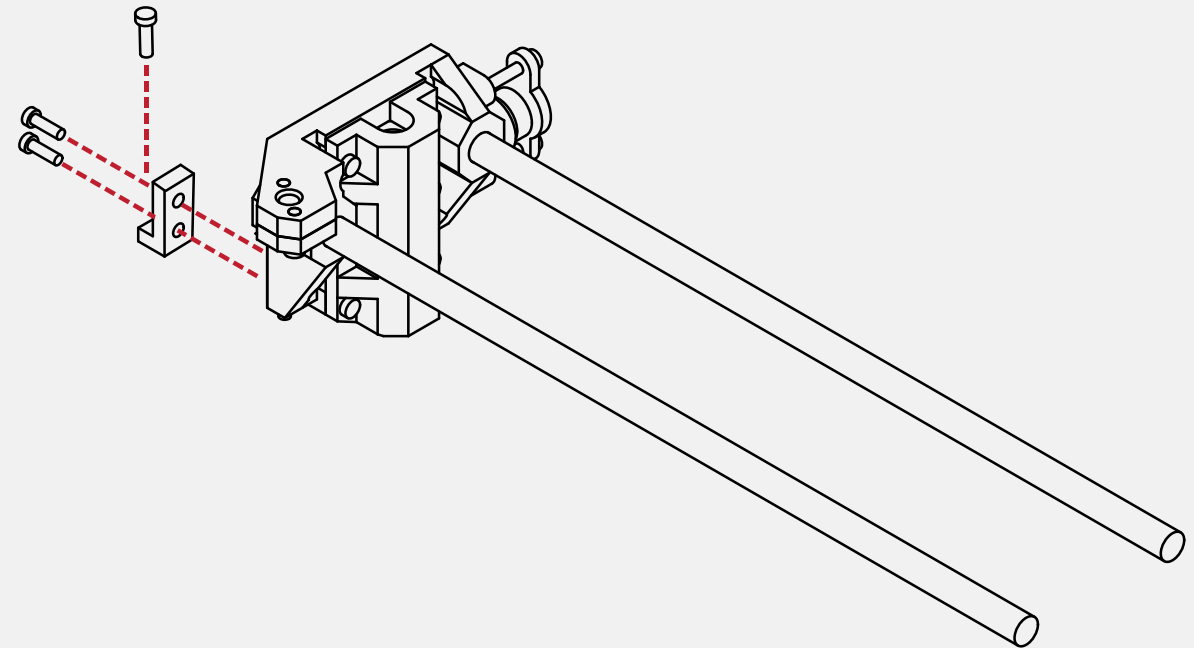

X 2

 M3 x 10

X 1

 M3 x 20

Locate the **Z Axis screw mount** from your parts kit, along with **2 M3 X 10**, and **1 M3 X 20 screws**.

Using your **hex wrench**, attach the Z axis screw mount to the outside of the X axis assembly.

Take the remaining **M3 X 20 screw** and screw it partially through the mount. This will be used to level your initial layer height later on.

16

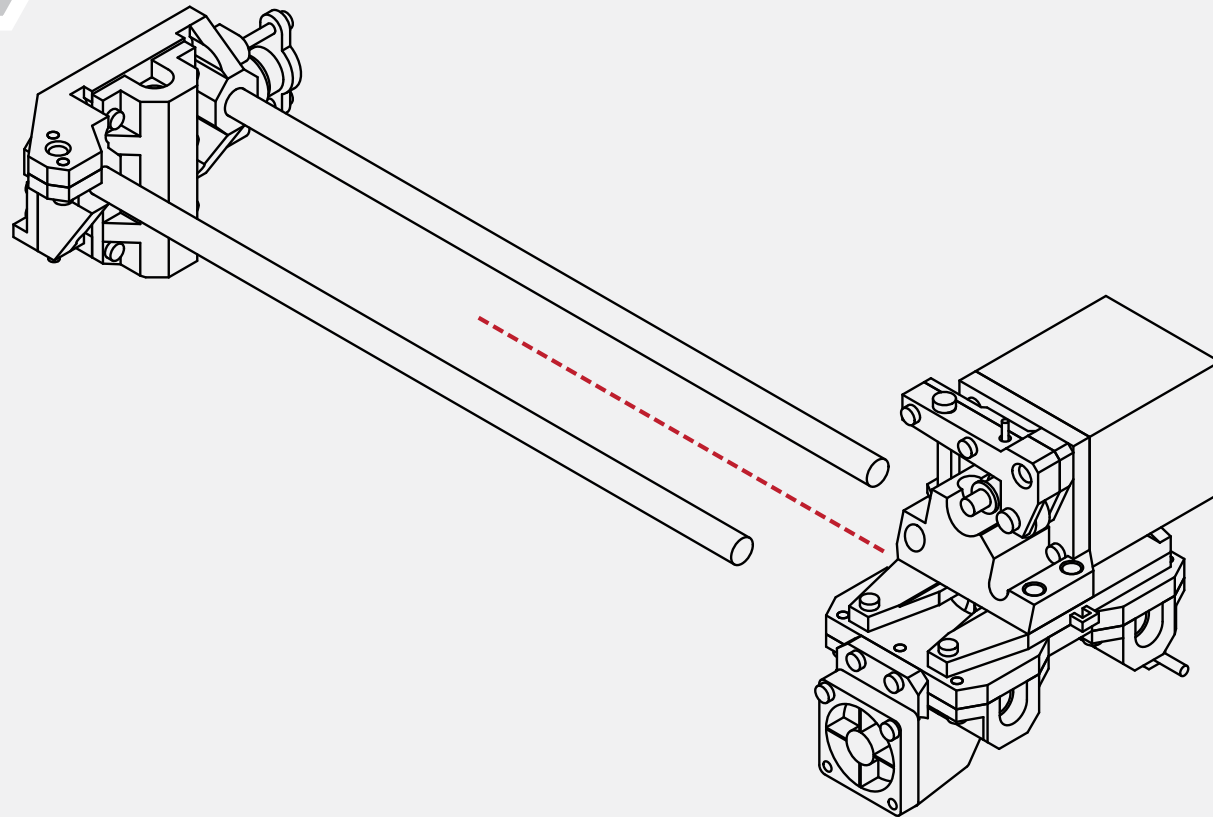

Locate the **Extruder assembly** that we assembled earlier in this guide.

N/A

Orientate the extruder so that the hot-end cooling fan is facing the X axis assembly.

Carefully slide the extruder assembly onto the linear rods.

Be careful when doing so, as it is easy to mis-align the rods, and damage the bearings.

17

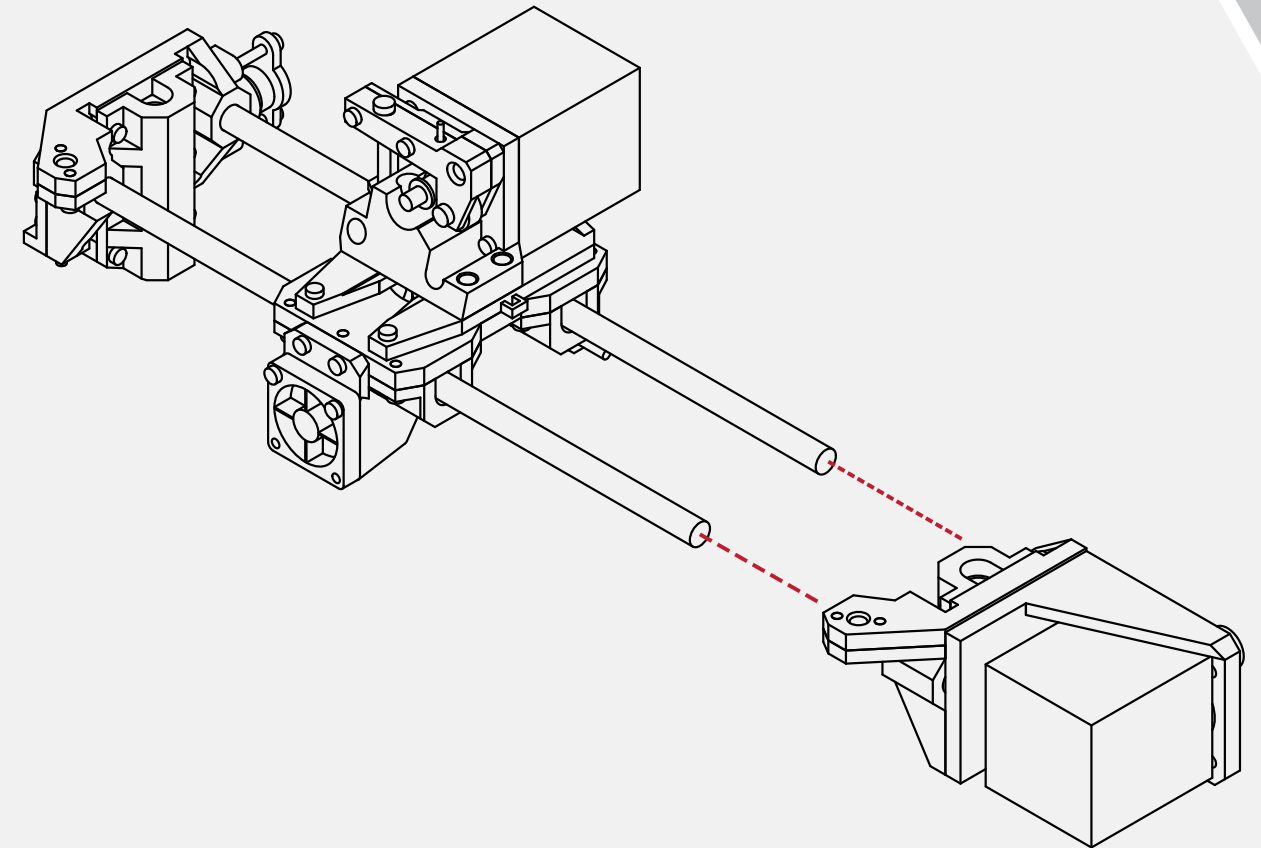

N/A

With the extruder assembly in place, collect the right **X axis assembly** that we assembled earlier.

Using a soft mallet, gently insert the X axis assembly onto the linear rods.

Take care not to damage the X assembly or linear rods.

If you find it particularly difficult, you can remove the 4 screws holding the motor assembly, and use the backside of X axis to hammer against directly. The linear rods should be flush with the backside of the X axis assembly.

18

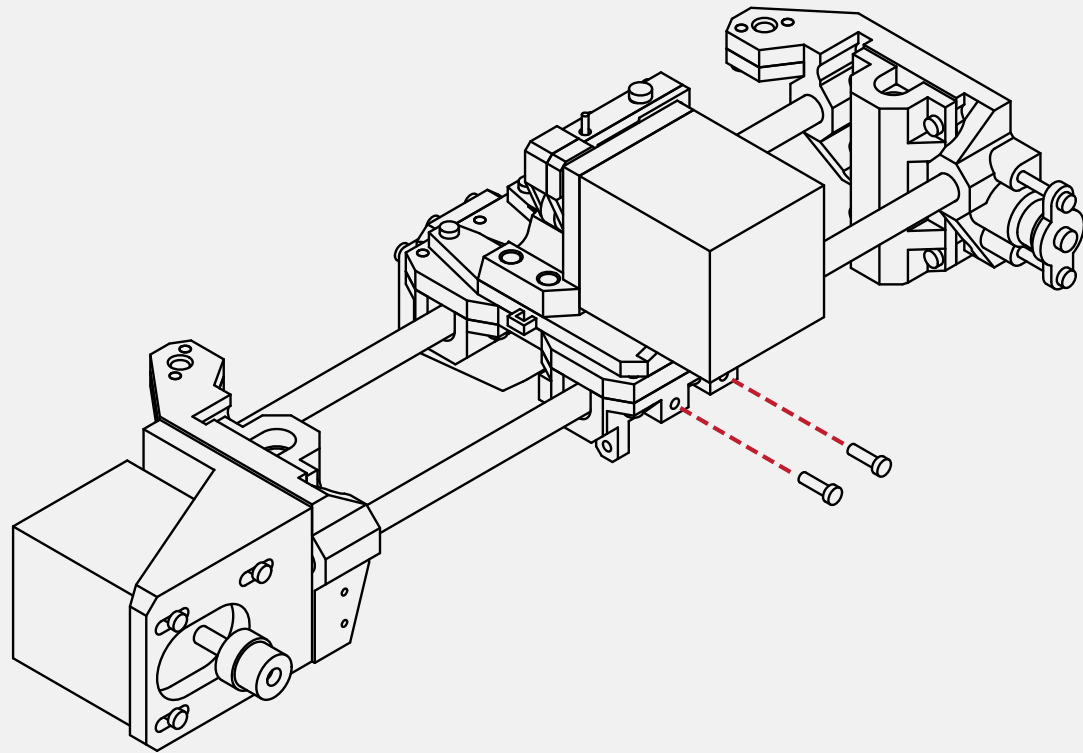

From your hardware kit, select **2 M3 X 10 screws**.

Using your hex **wrench**, insert the screws into the backside of the extruder assembly.

The screws should sit roughly 6mm proud of the extruder assembly. These will be used later in this guide to secure the GT2 belts.

X 2



19

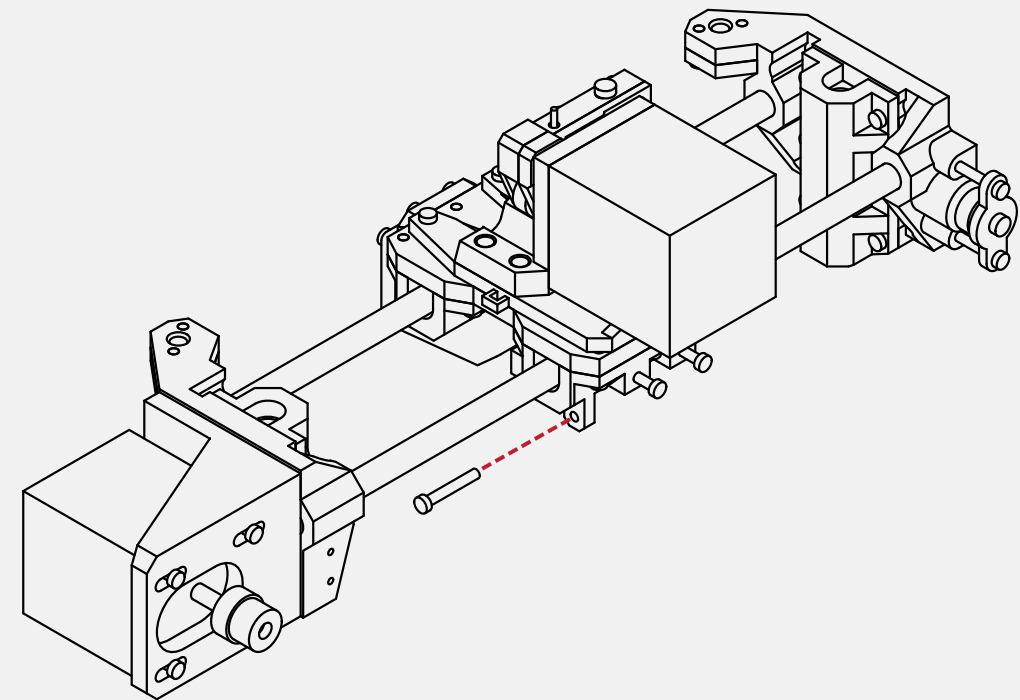

X 1



Locate **1 M3 X 20 screw** from your hardware kit.

Using your **hex wrench**, insert the screw partially into the extruder assembly.

This screw will be used later to adjust your X axis end-stop.

1

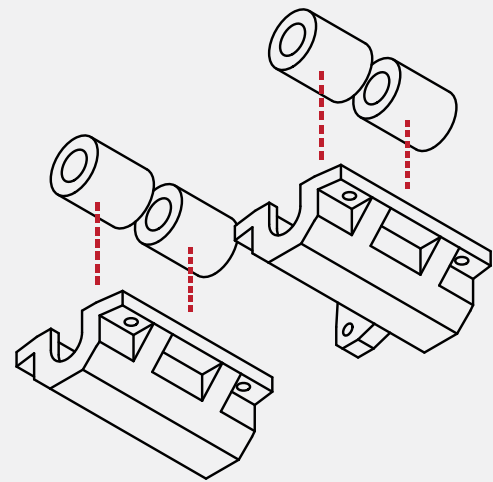

Locate the **lower Y bearing carriers**, and **4 linear bearings** from your parts kit.

N/A

Insert the bearings into the bearing carriers.

Ensure that the bearings are fully seated before proceeding.

2

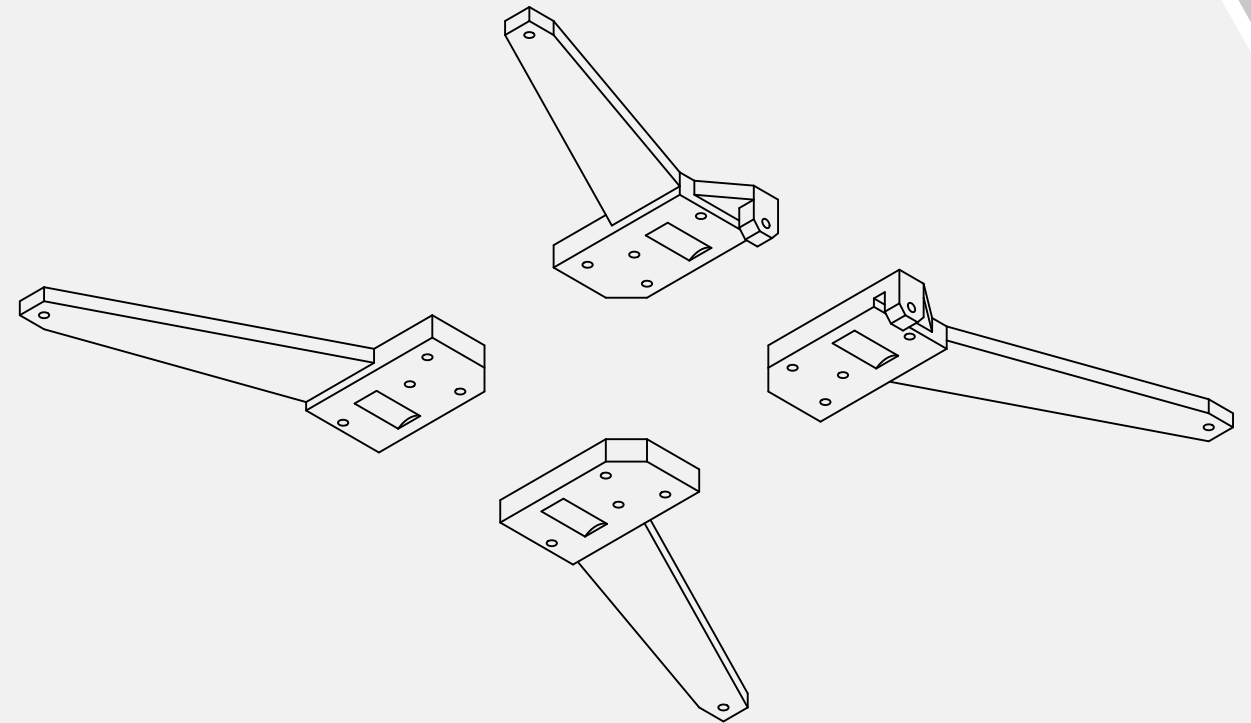

N/A

Gather the **4 lower Y bed** pieces from your parts kit and arrange them like so.

3

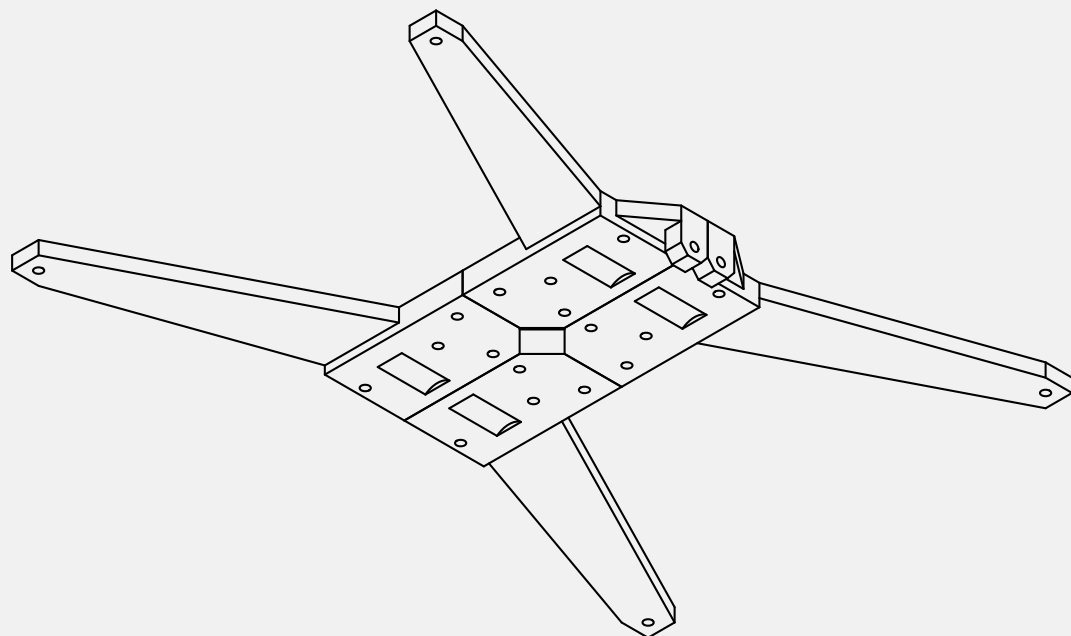

Arrange the lower Y bed pieces such that the indentations for the bearings align.

N/A

Ensure that the pieces fit well.

You may use a sharp Exacto-knife or file to trim any parts that do not fit well.

4

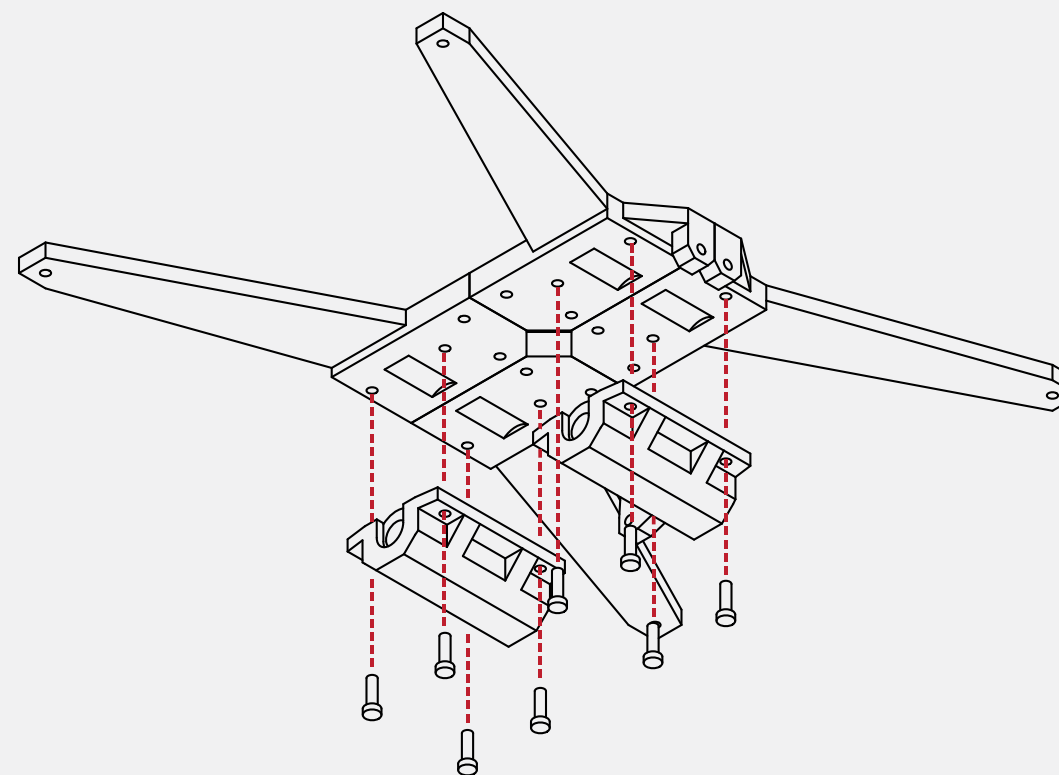

X 8

 M3 x 10

From your hardware kit, locate **8 M3 X 10 screws**. Gather the bearing carriers that were assembled previously.

Using your **hex wrench**, install the 8 screws into the bearing carriers, and then into the Y bed frame components.

5

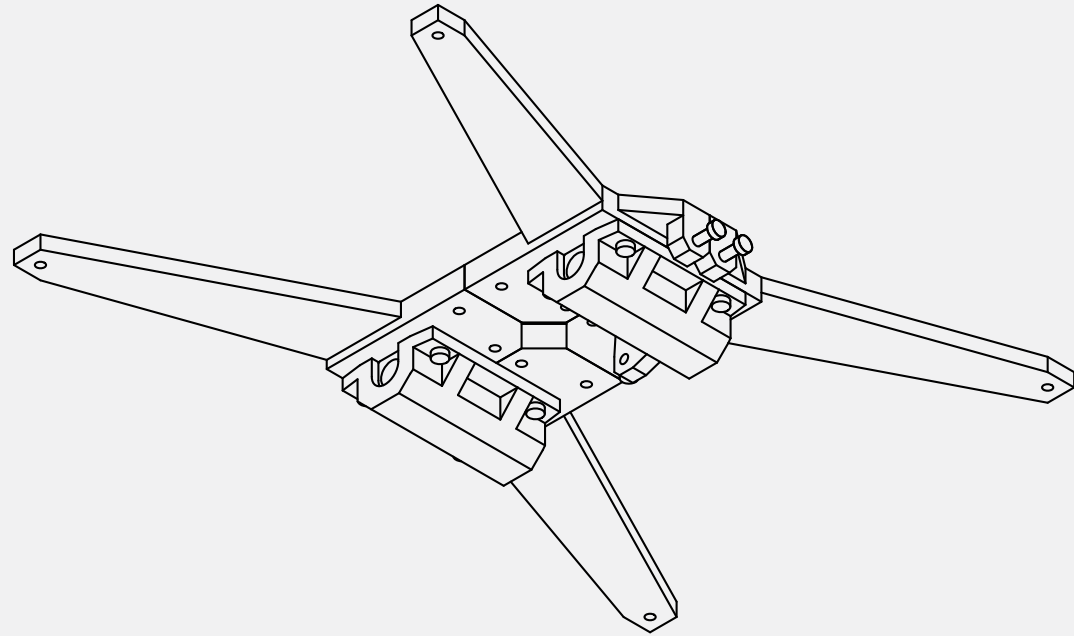

Ensure that all parts fit correctly and that all screws are tight.

N/A

The bearings should be firmly captured in their carriers and should have little play in them.

6

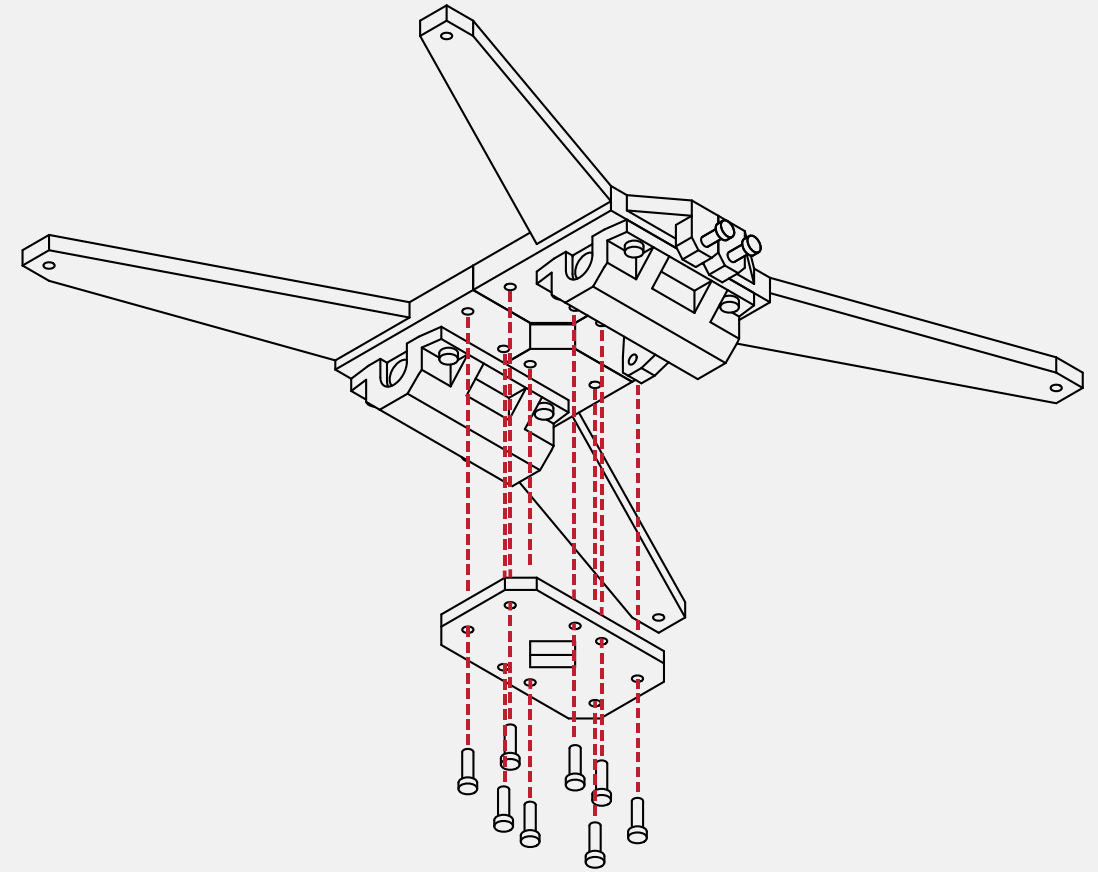

X 8

 M3 x 10

Locate the **Y bed cross member** from your parts kit, along with **8 M3 X 10 screws**.

Using your **hex wrench**, install the screws into the cross member, and then into the lower bed assembly.

7

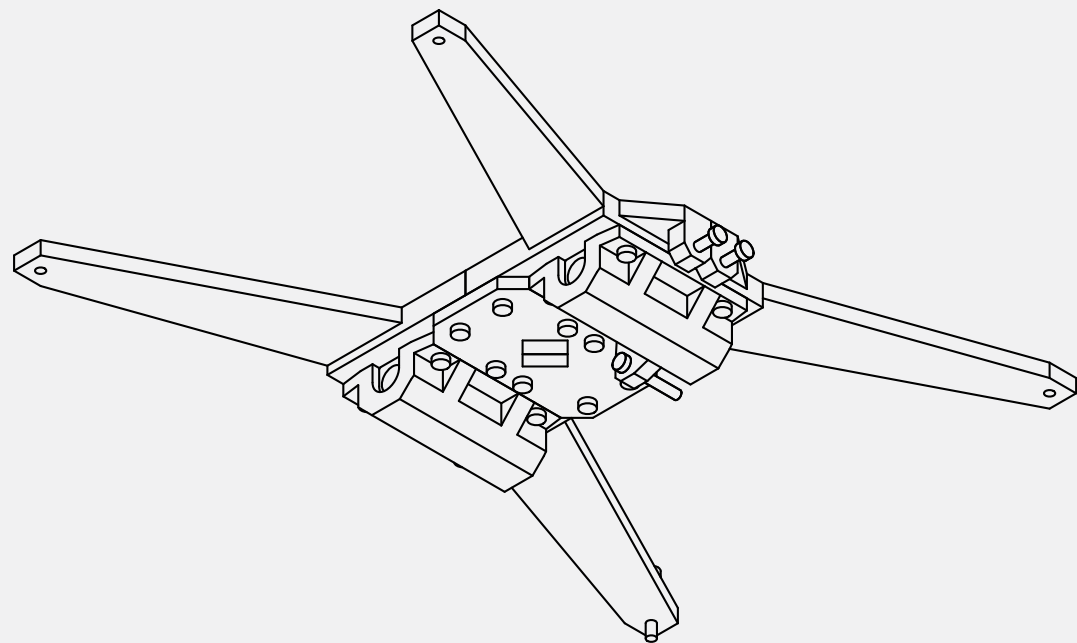

With the cross member installed, ensure that all parts fit well and that all screws are tight.

N/A

8

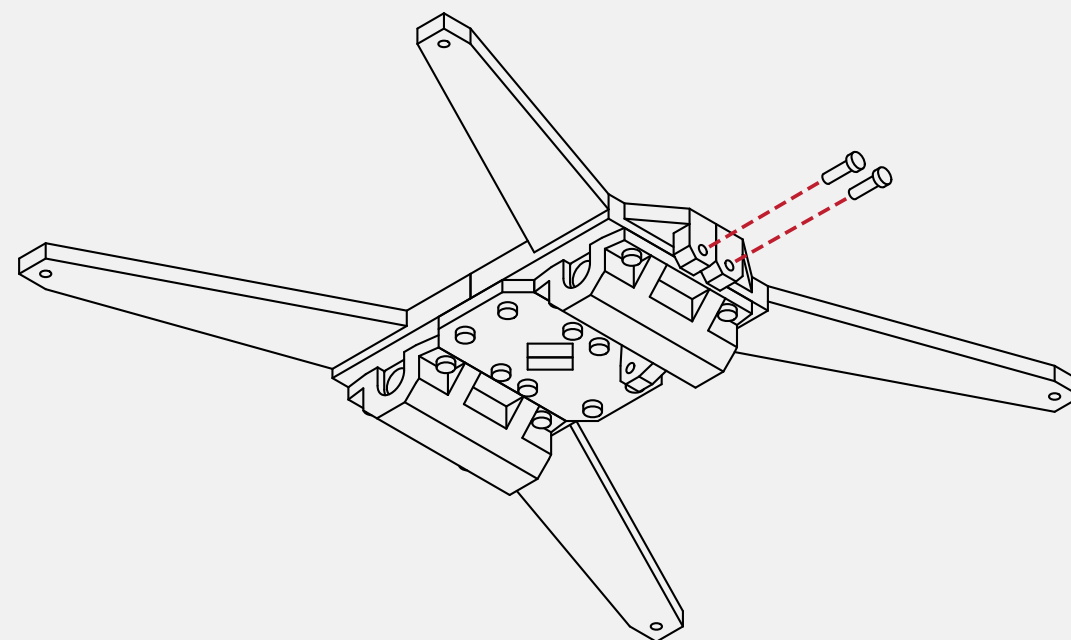

X 2

 M3 x 10

Locate **2 M3 X 10 screws** from your hardware kit.

Insert the screws into the 2 mounting points on the side of the lower bed.

The screws should sit 6mm proud of the mount.

These screws will be used to secure the GT2 belt to later in this guide.

7

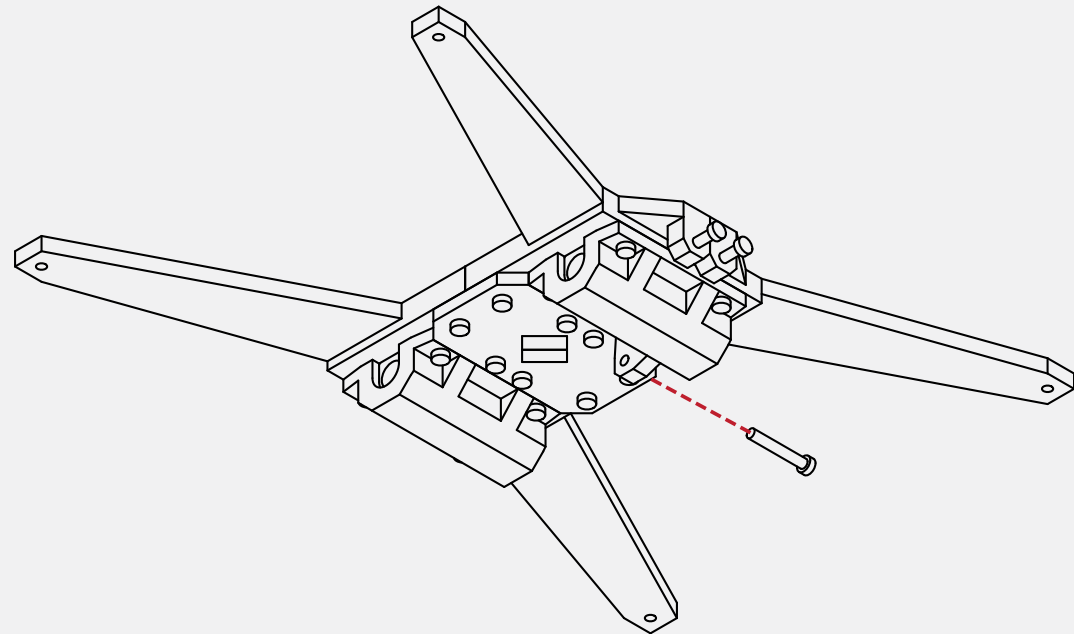

Locate 1 **M3 X 20 screw** from your hardware kit and install it into the screw mount on the rear of the lower bed assembly.

This screw will be used to home the bed later in your configuration.

X 1



M3 x 20

8

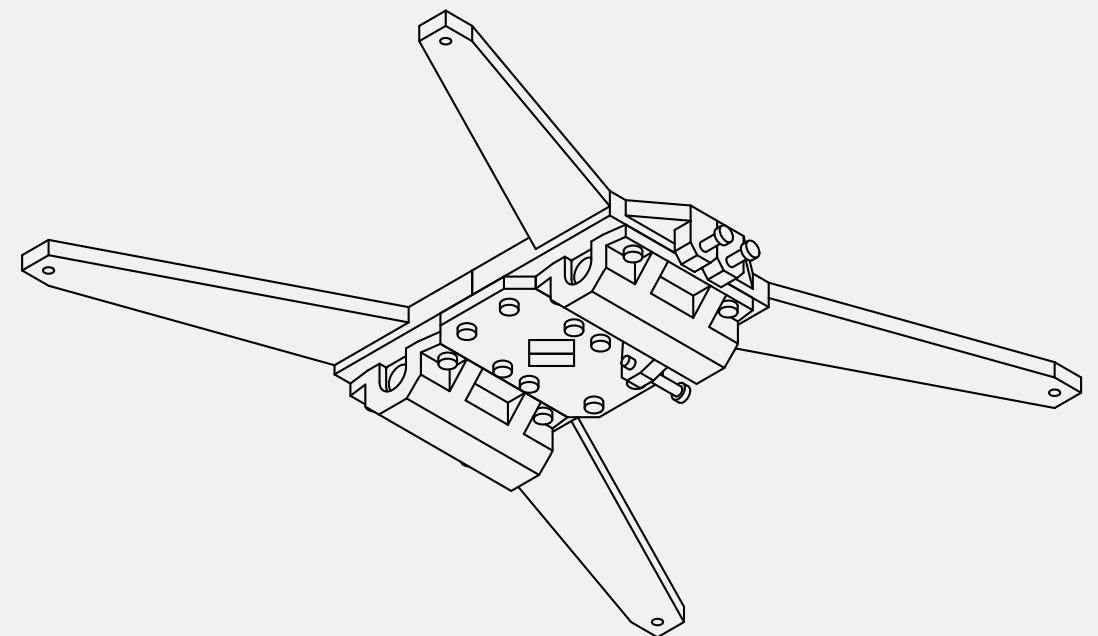

N/A

Congratulations! The lower bed assembly is complete!

Double check that all the fasteners are tight and that all the parts are properly aligned.

9

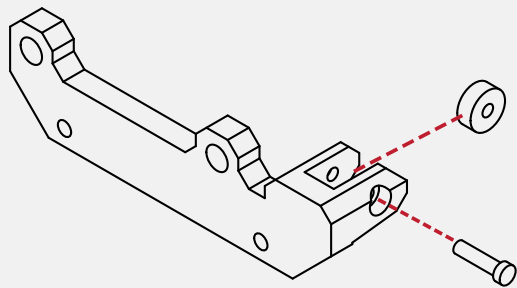

From your parts kit, locate the front Y axis carrier. Locate **1 bearing and 1 M4 X 16 screw** from your hardware kit.

Insert the bearing into the bearing holder, and using youe **hex wrench**, insert the screw into the bearing holder and bearing.

X 1



M4 x 16

10

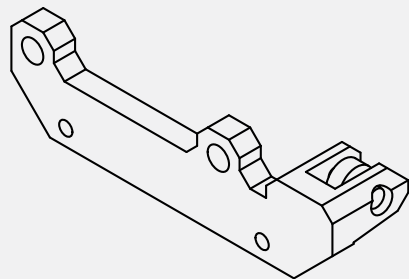

Ensure that the bearing can rotate freely in its holder.

This bearing will act as the idler for the GT2 belt which will be installed later in this guide.

N/A

11

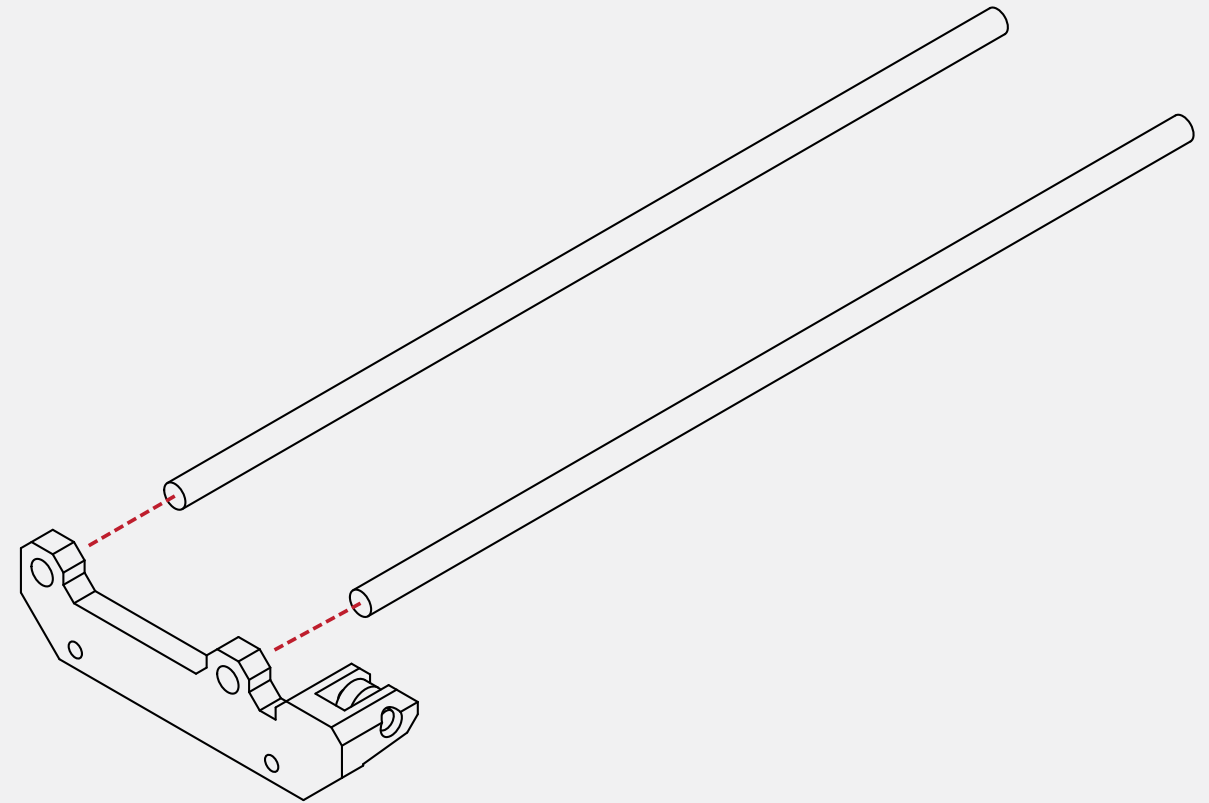

N/A

Locate the **longest linear rods** from your hardware kit.

Using a soft mallet, gently insert the linear rails into the Y axis carrier.

Take care to ensure the rods are square and that the carrier is not damaged.

When fully inserted, the face of the rods should be flush with the face of the carrier.

12

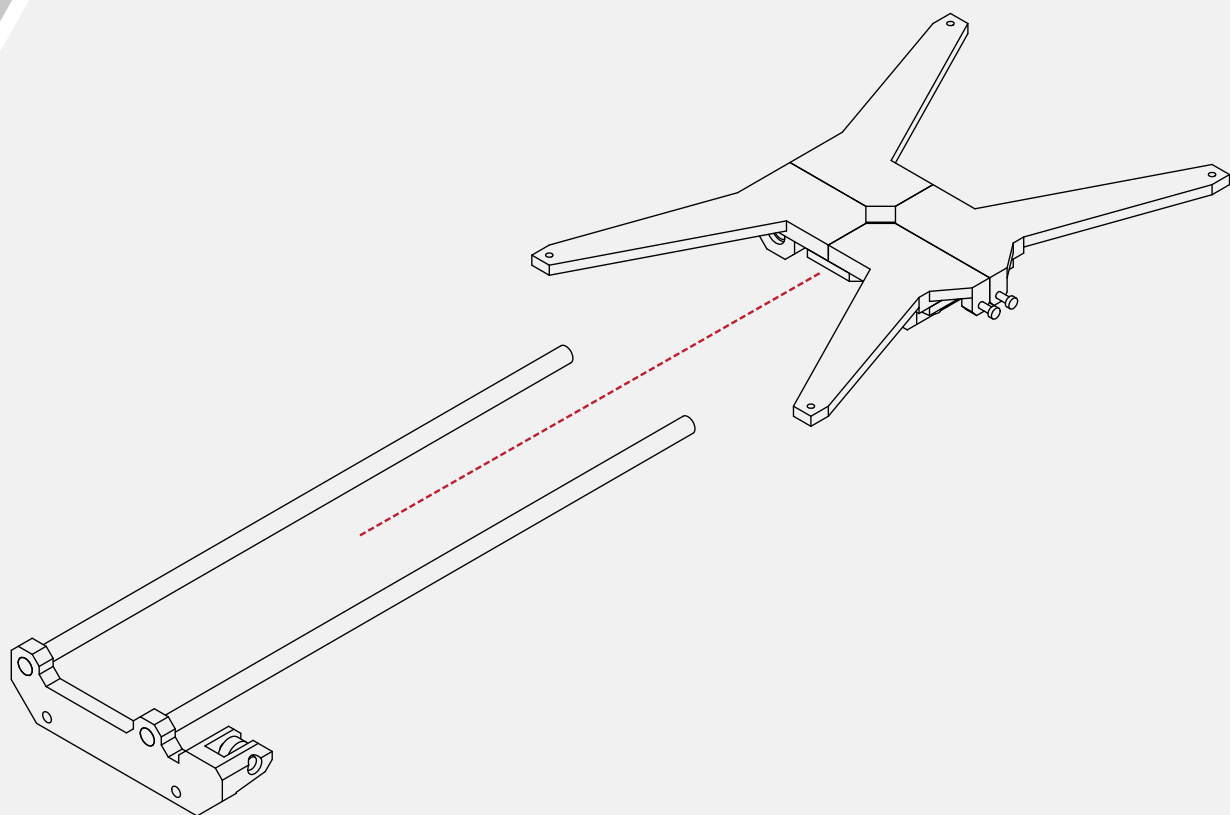

Take the **lower Y bed** from the previous steps and carefully insert the **lower Y carriage** assembly.

Take care when guiding the linear rods through the bearings.

The bearings can easily be damaged if the rods are mis-aligned or excessive force is used when inserting them into the bearings.

N/A

13

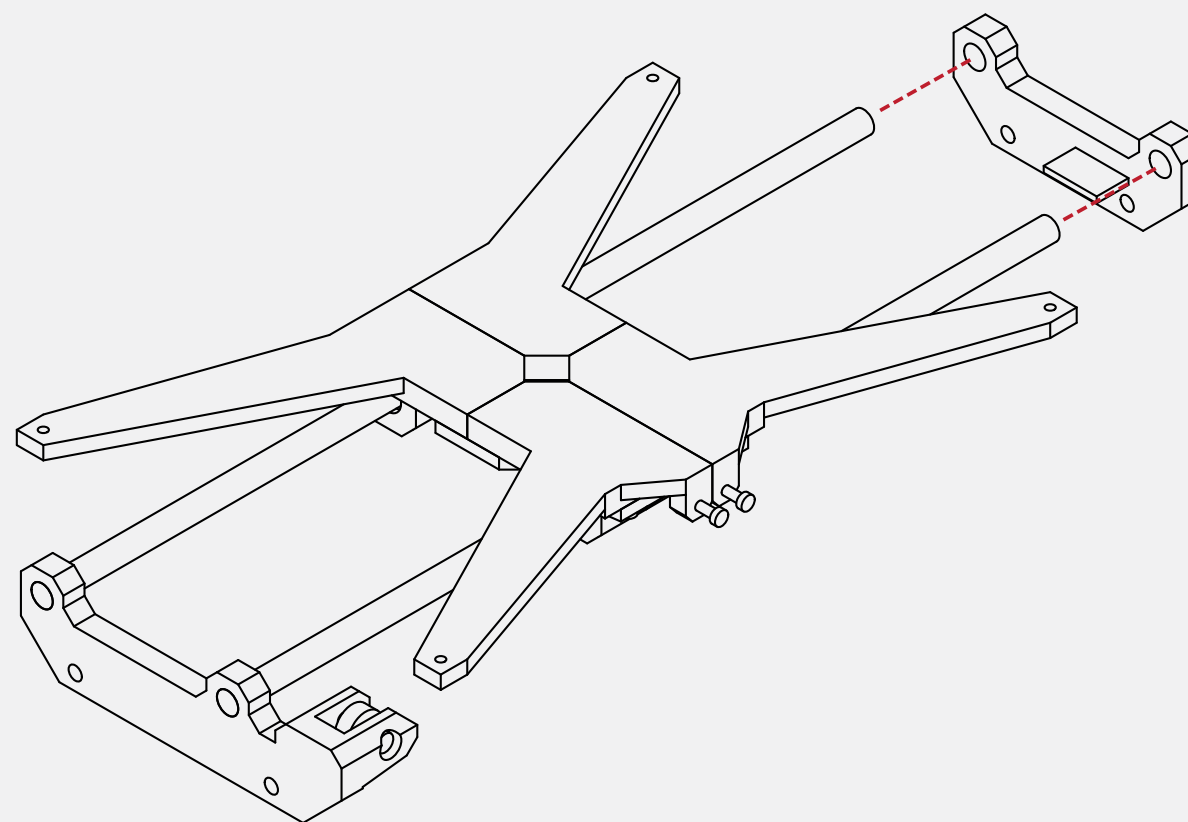

N/A

Locate the **rear Y carrier** from your parts kit.

Using a soft mallet, gently insert the carrier onto the existing assembly.

Take care to not damage the rear carrier.

When fully inserted, the faces of the linear rods should be flush with the face of the rear carrier.

1

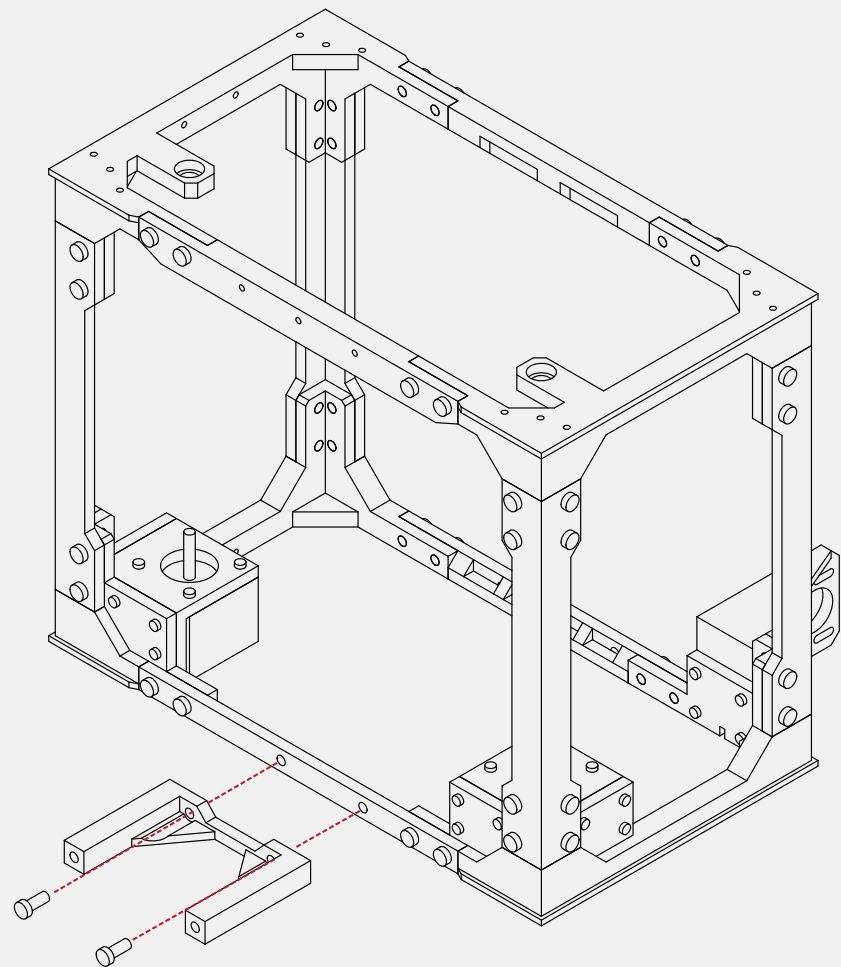

Take the **front Y axis mount** from your parts kit, and gather **2 M5 X 12 screws**.

X 2



Using your **hex wrench**, attach the Y axis mount to the front frame of the printer.

Ensure that the screws are tight and that the parts fit correctly.

2

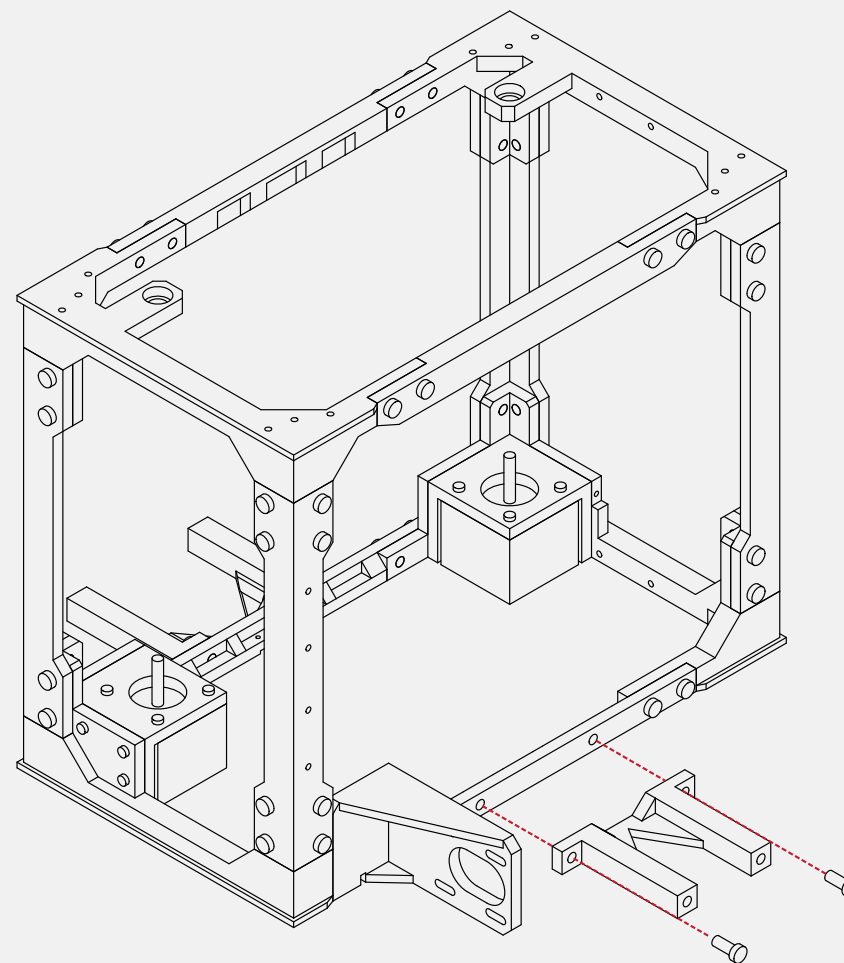

X 2



Repeat the same procedure for the rear, using the **rear Y axis mount** and **2 M5 X 12 screws**.

Ensure that the part is tight to the frame and that both screws are tight.

3

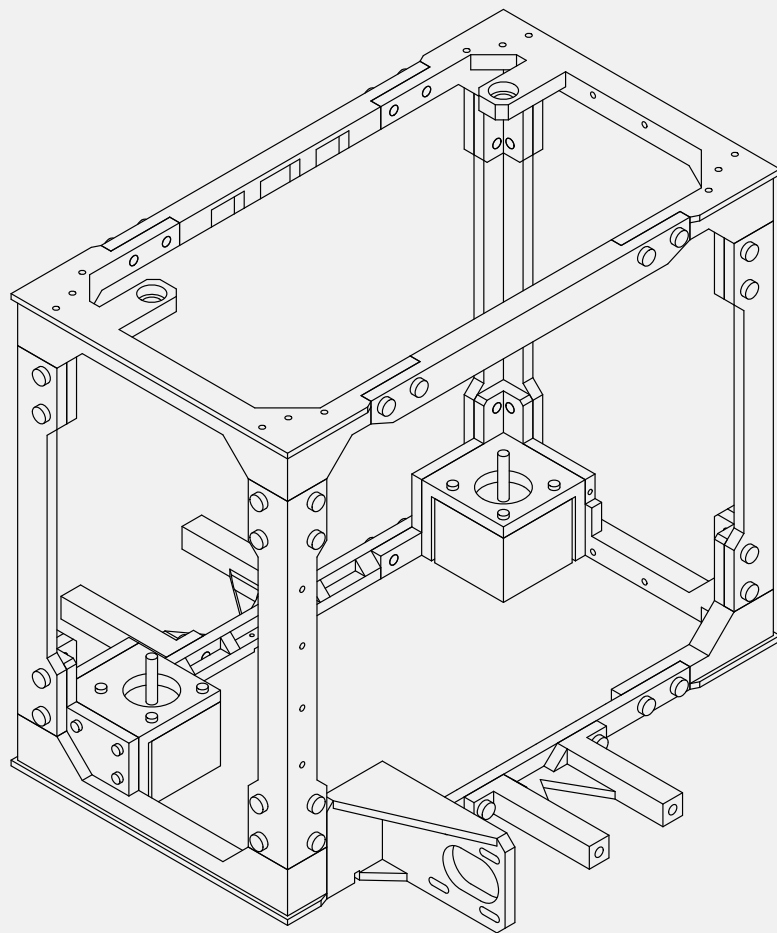

Congratulations, the front and rear Y axis mounts are installed.

N/A

Before proceeding, double check that all connections are tight and that the parts fit correctly.

4

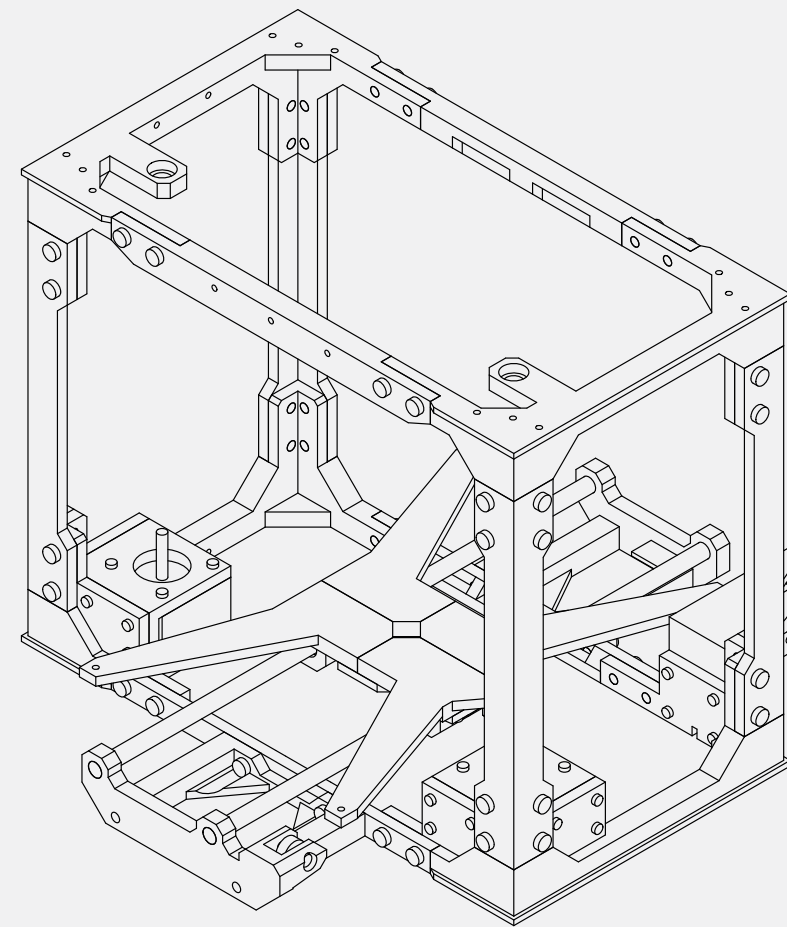

N/A

Locate the **lower bed assembly** that we completed earlier in this guide.

Insert the lower bed assembly into the frame of the printer, and over top of the Y axis mounts.

If everything aligns, the lower bed assembly should drop into place on the Y axis mounts.

If the lower bed does not fit, or there is unnecessary force needed to fit it, use a soft mallet on the inside of the Y axis carriers to lengthen them slightly and try again.

5

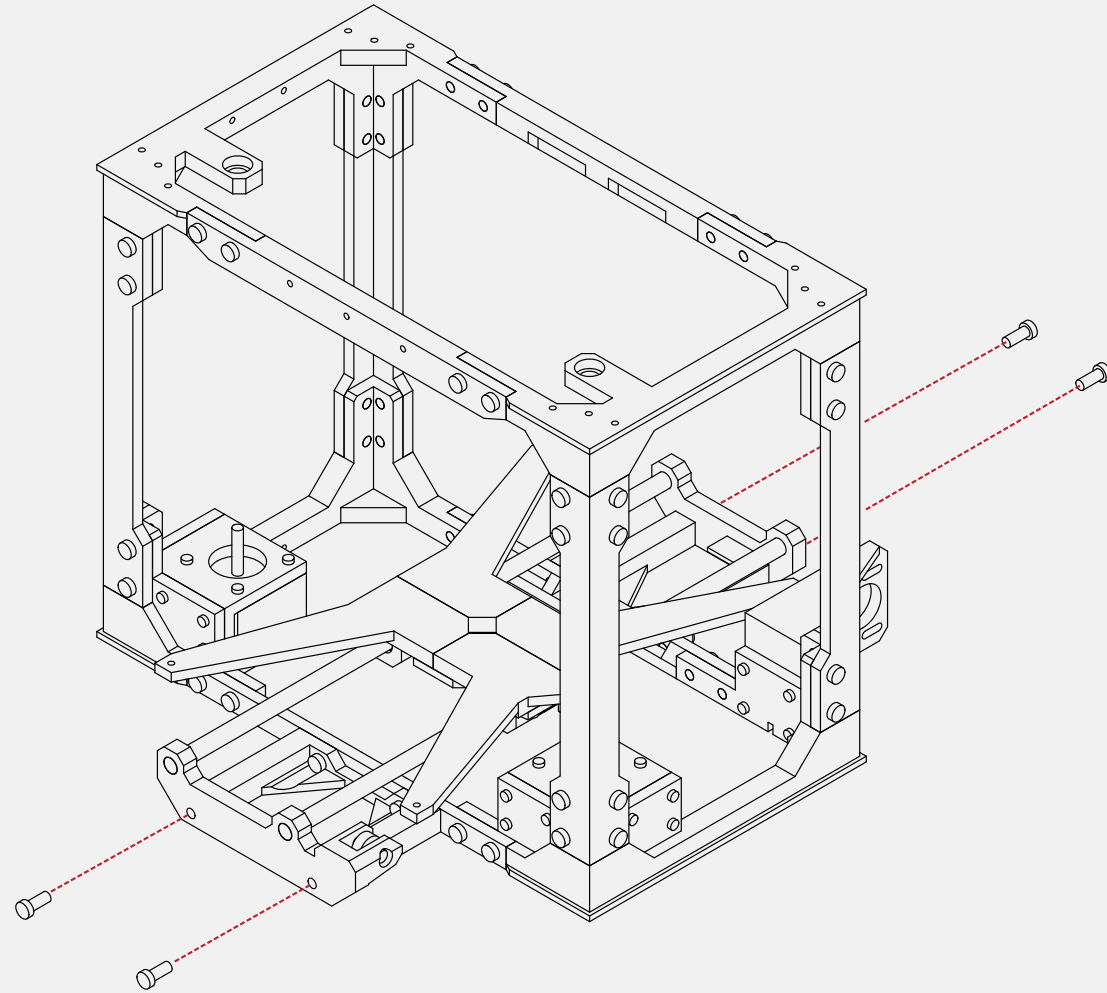

Locate **4 M5 X 12 screws** from your hardware kit.

Using your **hex wrench**, install the screws through the Y axis carriers and into the Y axis mounts.

X 4



6

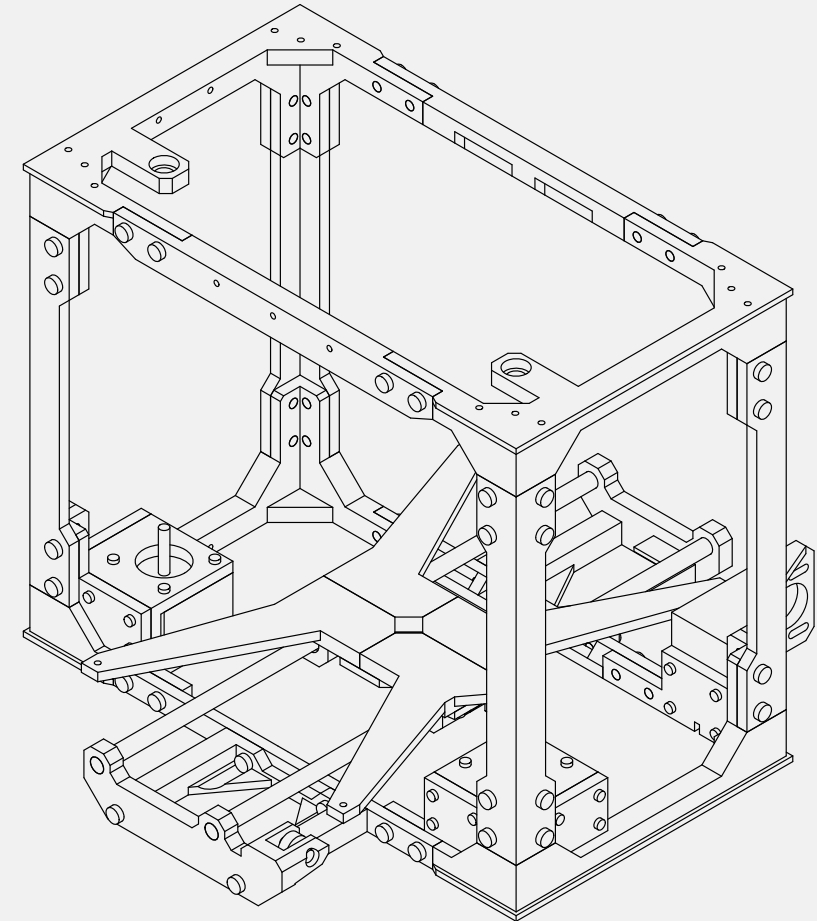

N/A

Congratulations! The lower bed installation is complete.

Double check that the screws are secure and that everything aligns properly.

Your printer should sit flat with little or no 'wobble'.

If there is any issues you may readjust the lower Y mount until suitable.

1

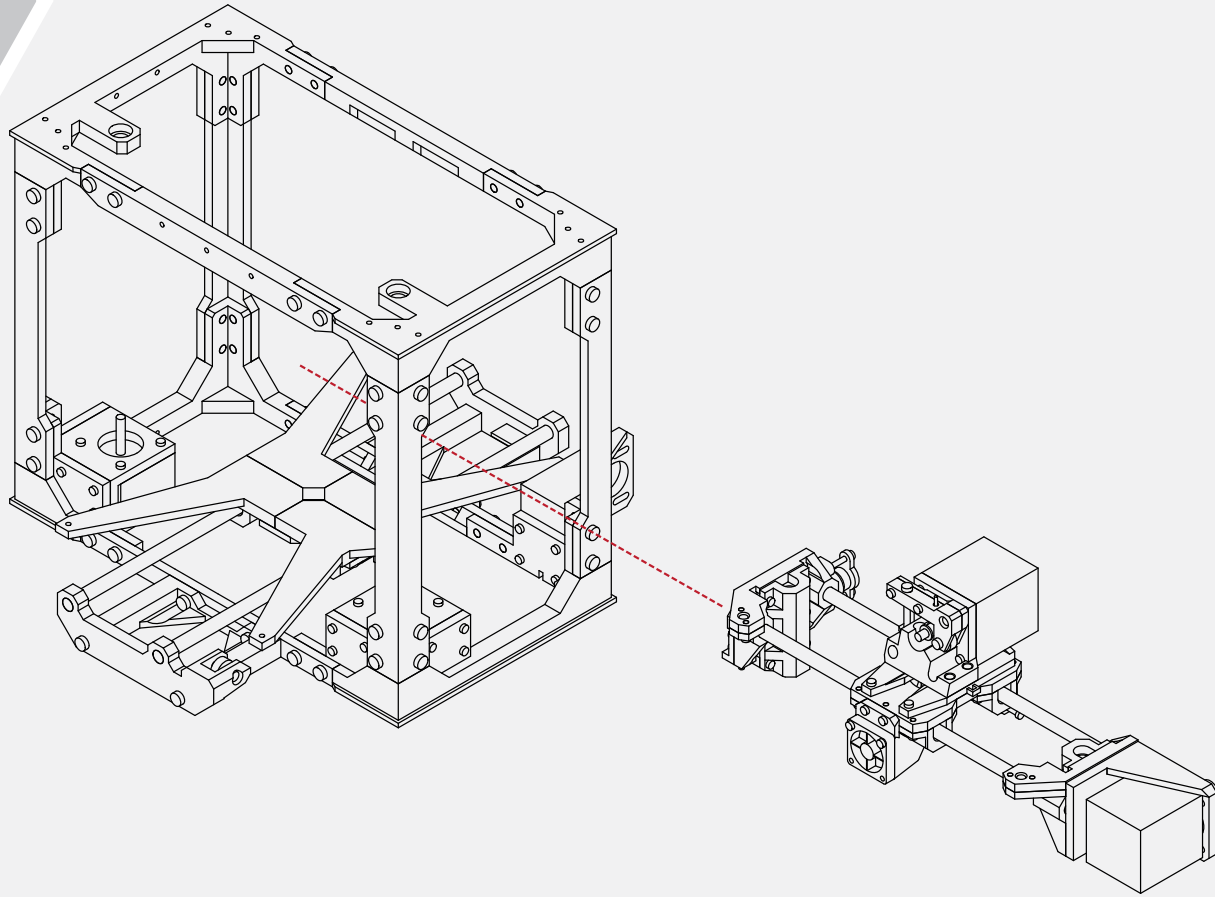

With the lower bed installed, locate the **X axis assembly** completed previously in this guide.

N/A

Insert the X axis assembly through the side of the frame.

The front of the extruder should face the front of the frame as well.

2

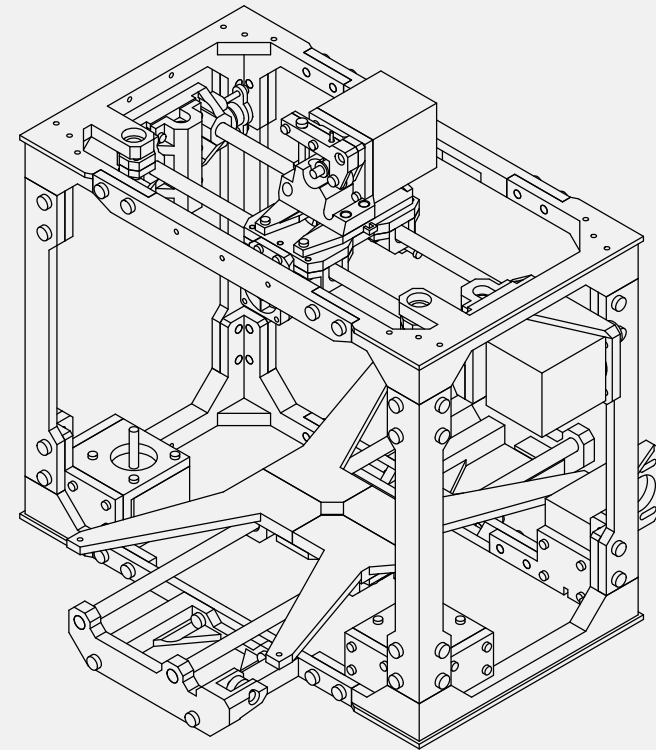

N/A

With the X axis assembly in the frame, it is advised that you temporarily secure the X axis to the top of the frame using cable ties or similar.

3

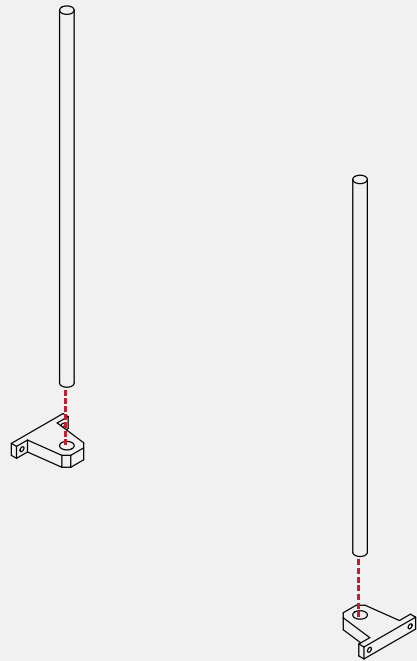

Locate the **Z axis carriers** from your parts kit, along with the remaining **2 linear rods**.

Using a **soft mallet**, insert the linear rods into the carriers.

When fully inserted, the face of the rod should be flush with the face of the carrier.

N/A

4

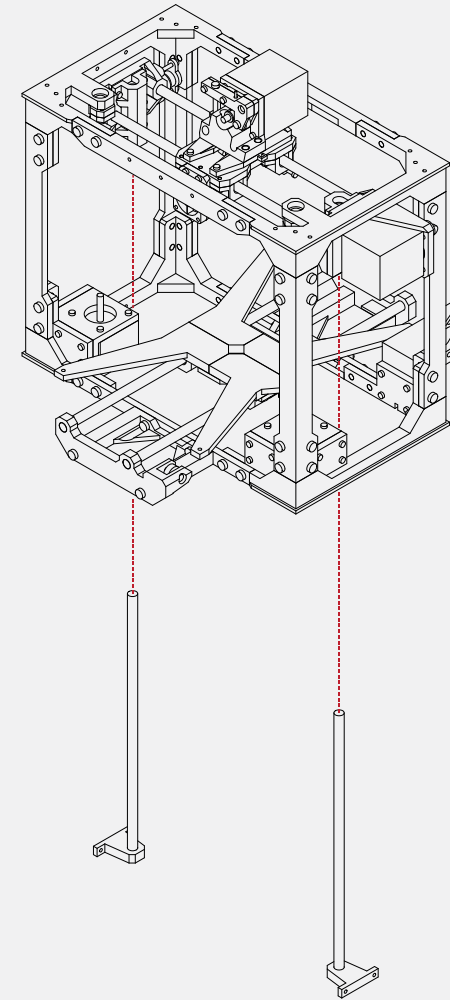

N/A

Take the **Z axis rods and carriers** assembled in the previous step and insert them through the bottom of the frame.

Insert the linear rods into the X axis assembly, taking care to not damage the linear bearings.

5

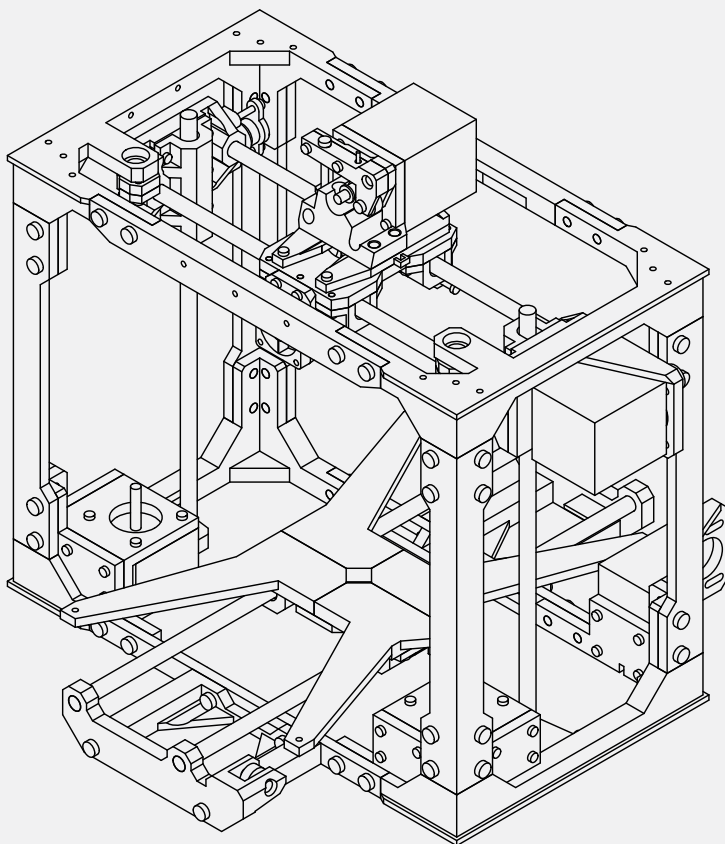

With the Z rods in place, check that there is no binding of the X axis and that everything is aligned before proceeding to the next step.

N/A

6

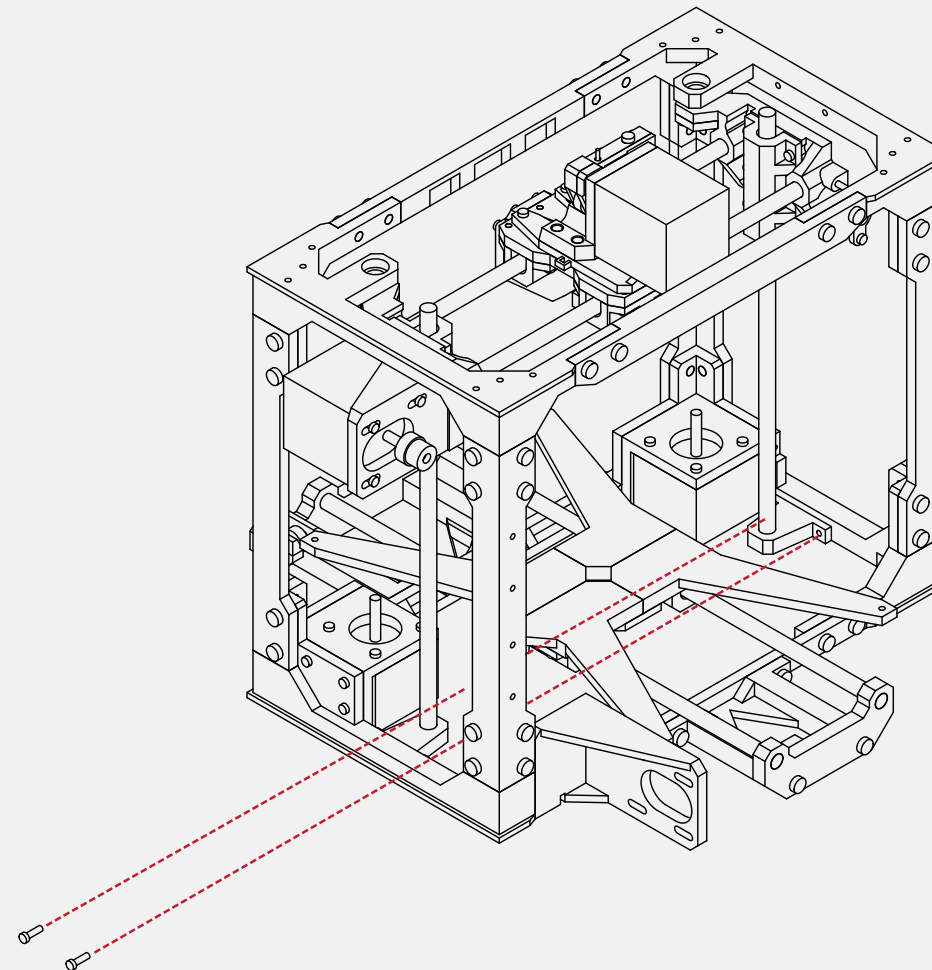

X 2

 M3 x 10

Gather 2 **M3 X 10 screws** from your hardware kit.

Using your **hex wrench**, install both screws through the ears of the Z axis mount and into the side of the frame.

Take care to ensure that the mount is tight against the frame and that the fasteners are secure.

7

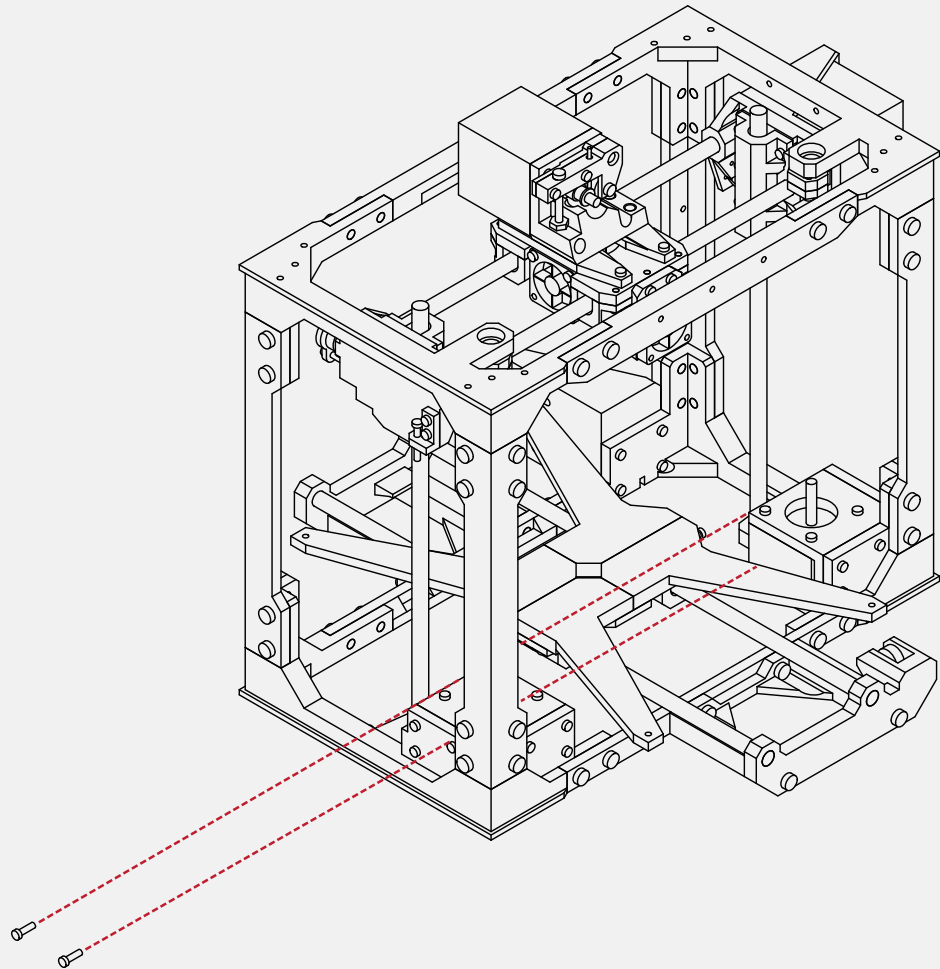

Repeat the same procedure in the last step, securing the opposite Z mount using **2 M3 X 10 screws**.

X 2



8

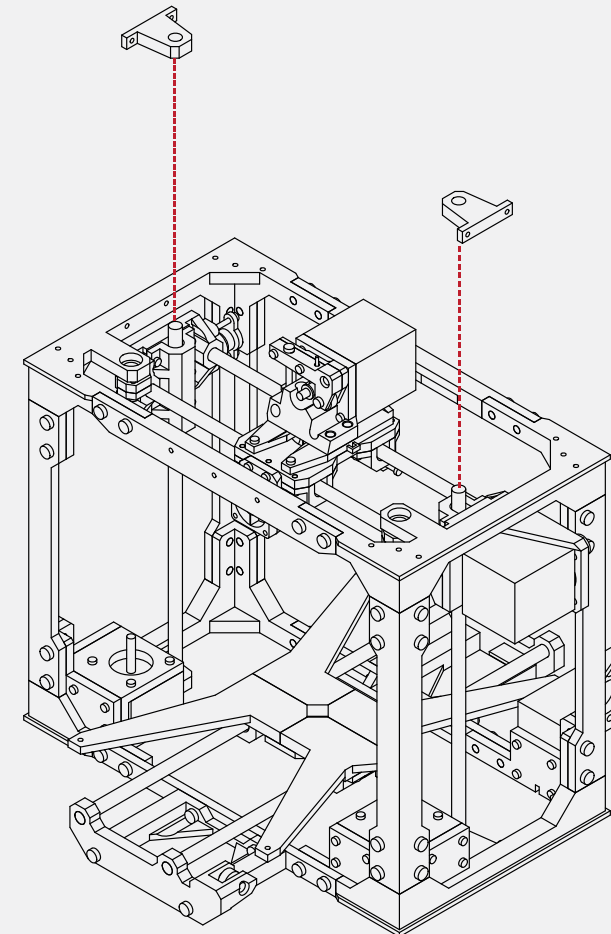

N/A

With the lower Z mounts secured to the frame, locate the remaining **2 Z mounts** from your parts kit.

Using a soft mallet, gently install the 2 mounts onto the linear rods.

When properly installed, the face of the Z mounts should be flush with the face of the linear rods.

9

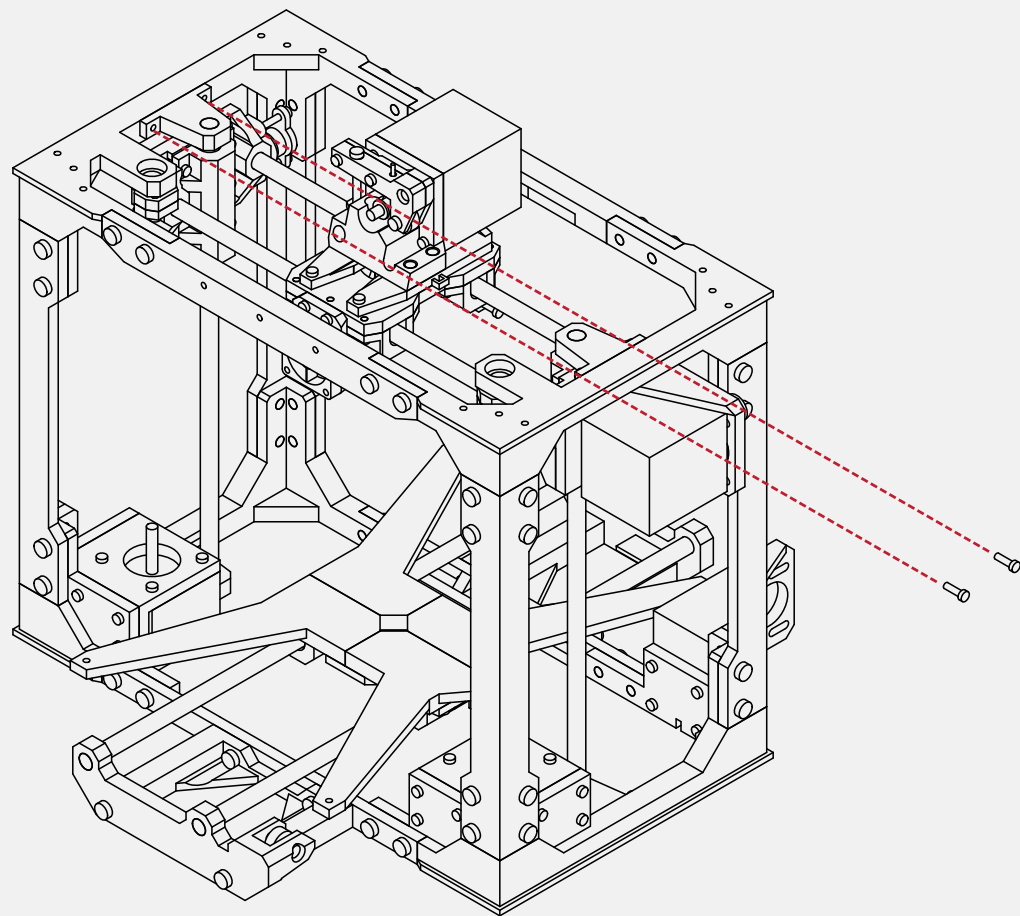

Similar to the previous steps, locate **2 M3 X 10 screws** and secure the top Z mounts. Ensure that the mounts are flush with the frame and that the fasteners are secure.

X 2



10

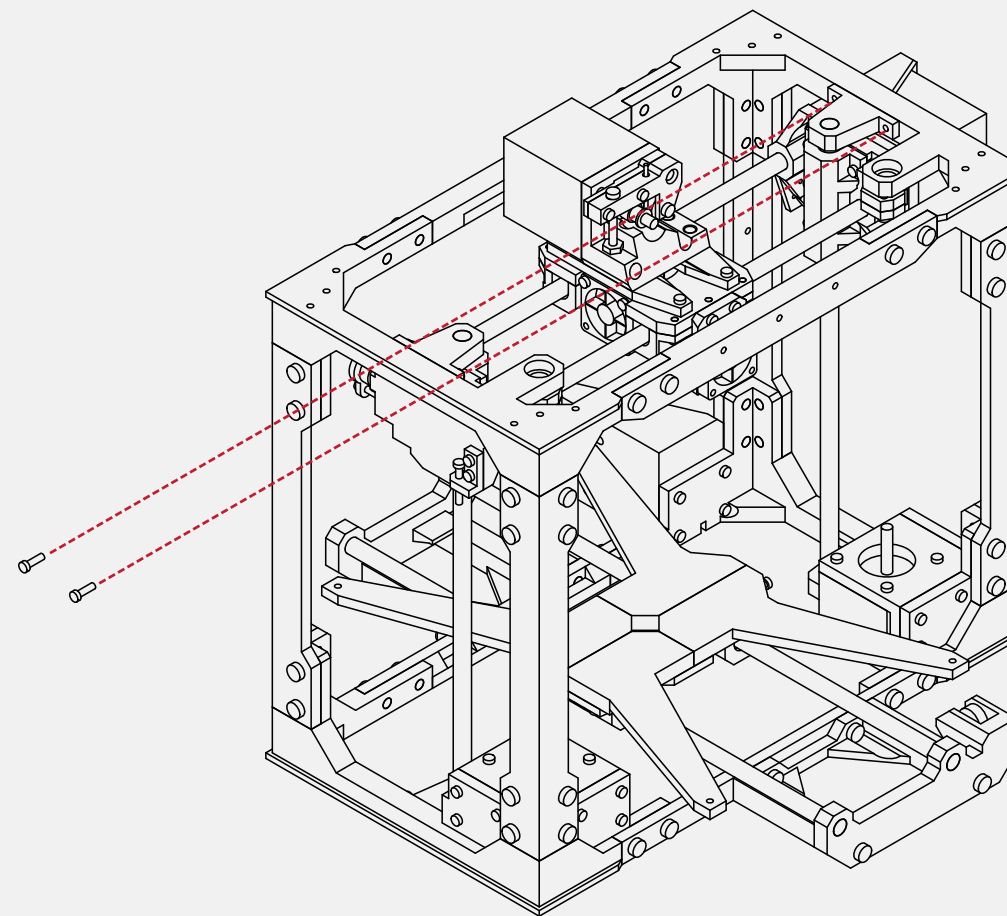

X 2



Repeat the same procedure for the opposite **Z mount**. Ensure that mount is flush with the frame, and that the fasteners are secure.

11

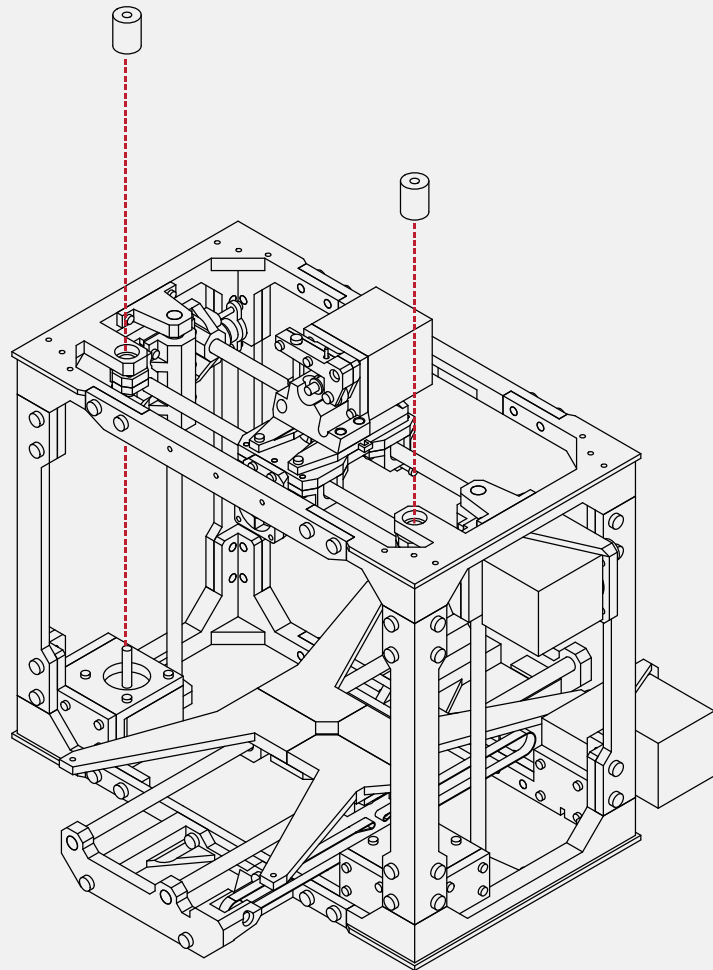

From your parts kit, locate the **Z couplers**.

N/A

Slide these couplers onto the shaft of the **Z axis stepper motors**.

Using your **hex wrench**, tighten the set screw on the coupler to secure it to the shaft.

12

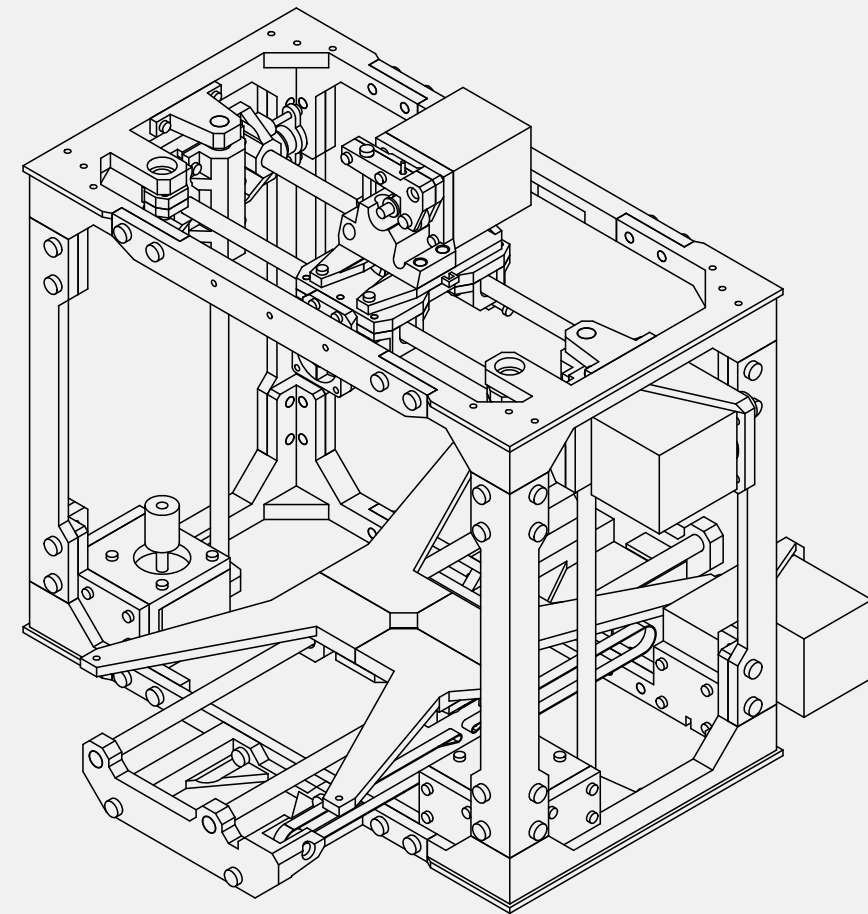

N/A

Ensure that the coupler is positioned half way onto the shaft.

The threaded rod will attach to these couplers in the following steps.

13

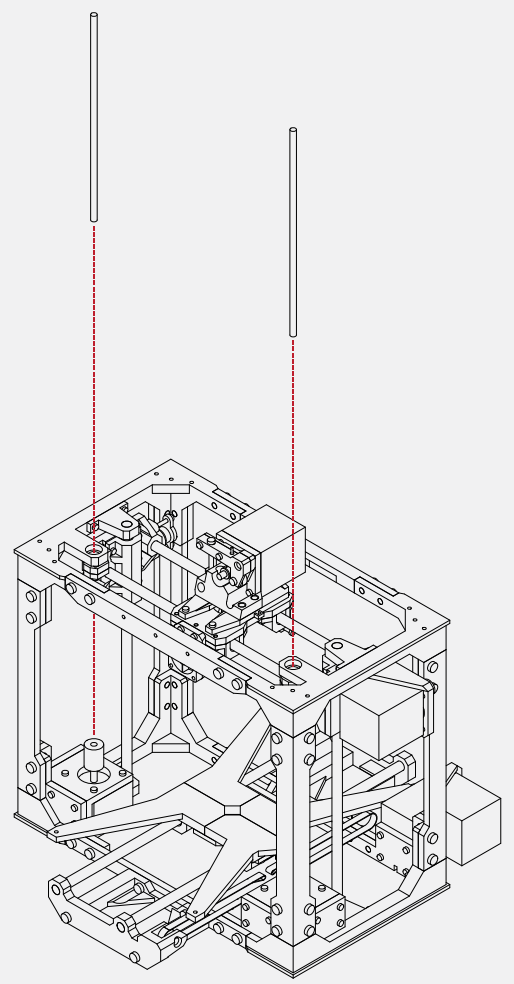

Locate the **threaded rods** from your parts kit.

N/A

Insert the rods through the top of the frame and thread the rods through the X axis mounts and into the couplers installed previously.

Using your **hex wrench**, tighten the set screws on the couplers to secure the threaded rod.

14

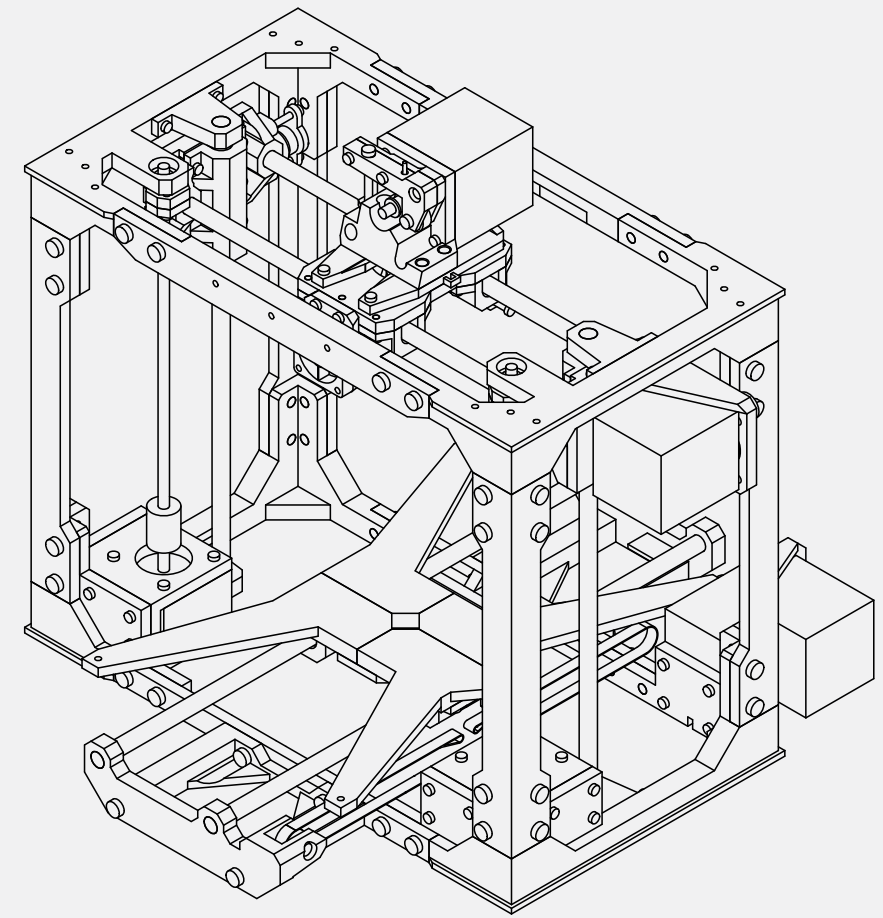

N/A

With both rods secure, check that the X axis is level.

If the X axis is uneven, simply turn either one of the threaded rods to raise or lower the axis until it appears close to level.

SECTION

E

<i>5.1 GT2 Belt Installation</i>	<i>98</i>
<i>5.2 LCD Installation</i>	<i>102</i>
<i>5.3 RAMPS Installation</i>	<i>106</i>
<i>5.4 Upper Bed Installation</i>	<i>116</i>
<i>5.5 Wiring & Final Configuration</i>	<i>118</i>

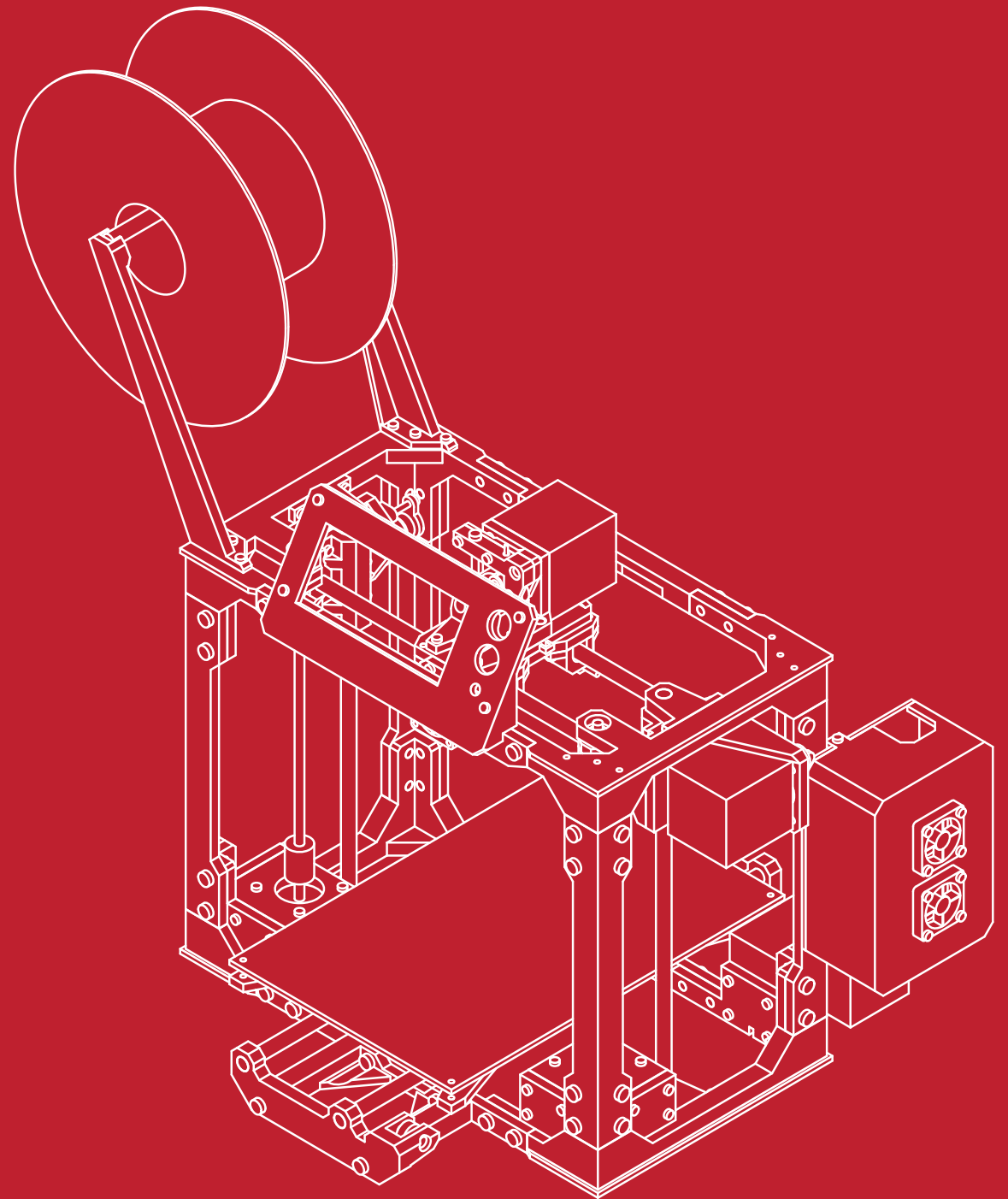

1

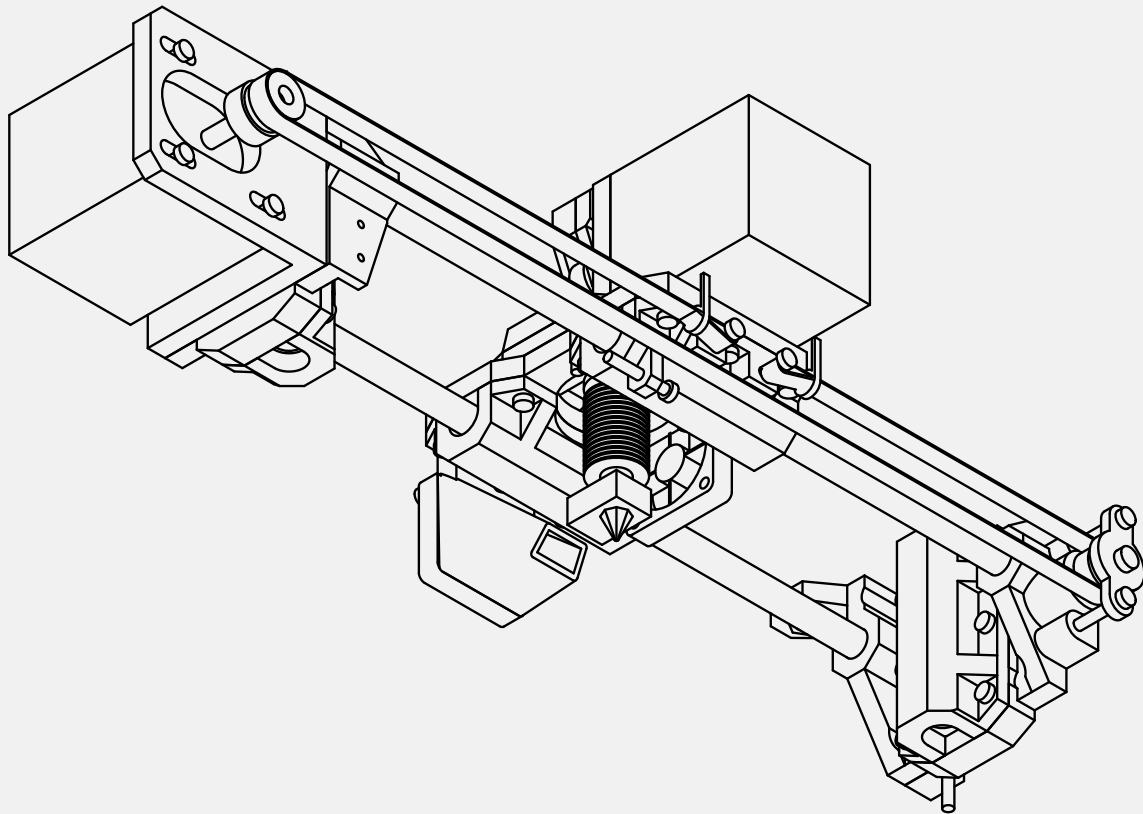

From your hardware kit, locate the **GT2 Belts**.

N/A

If not already cut, cut the belt to length so that it is long enough to loop around the motor, and opposite idler bearing with some extra length.

The belt will be mounted with the teeth facing inwards.

Take one end of the belt and loop it around one of the screws on the extruder assembly.

2

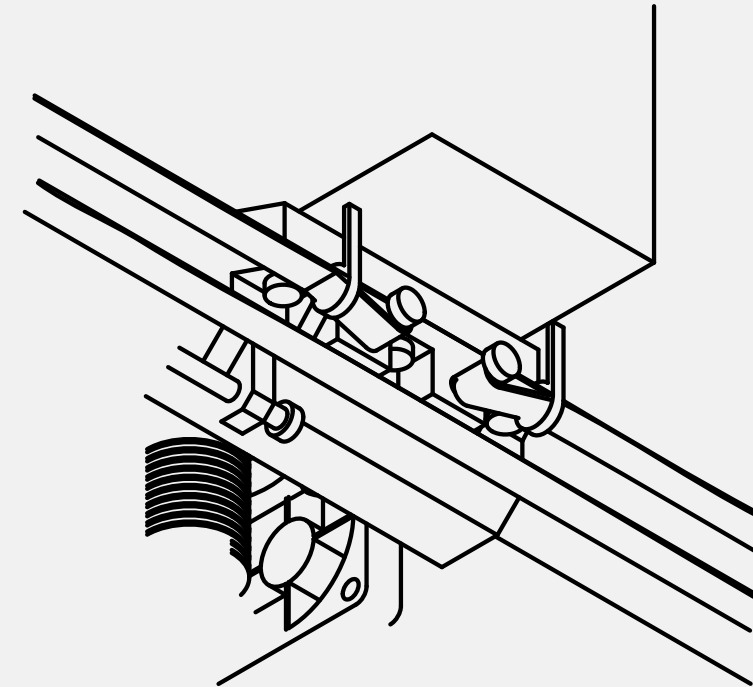

Secure this using a **cable tie** so that the belt teeth mesh together. Take the belt and loop it around the idler bearing and back around the pulley on the X axis motor.

Your belt should be long enough to reach the remaining screw on the extruder assembly.

While holding the extruder assembly in place, use a pair of pliers, or a second set of hands to pull the belt as tight as possible to remove any slack.

With the slack removed, secure the belt to the screw using the same method as before.

When complete, the belt should be tensioned and tight. If there is slack, you may loosen the 4 screws holding the motor in place and slide it backwards, away from the frame to tension the belt more.

Remember to tighten the motor mounts when complete.

3

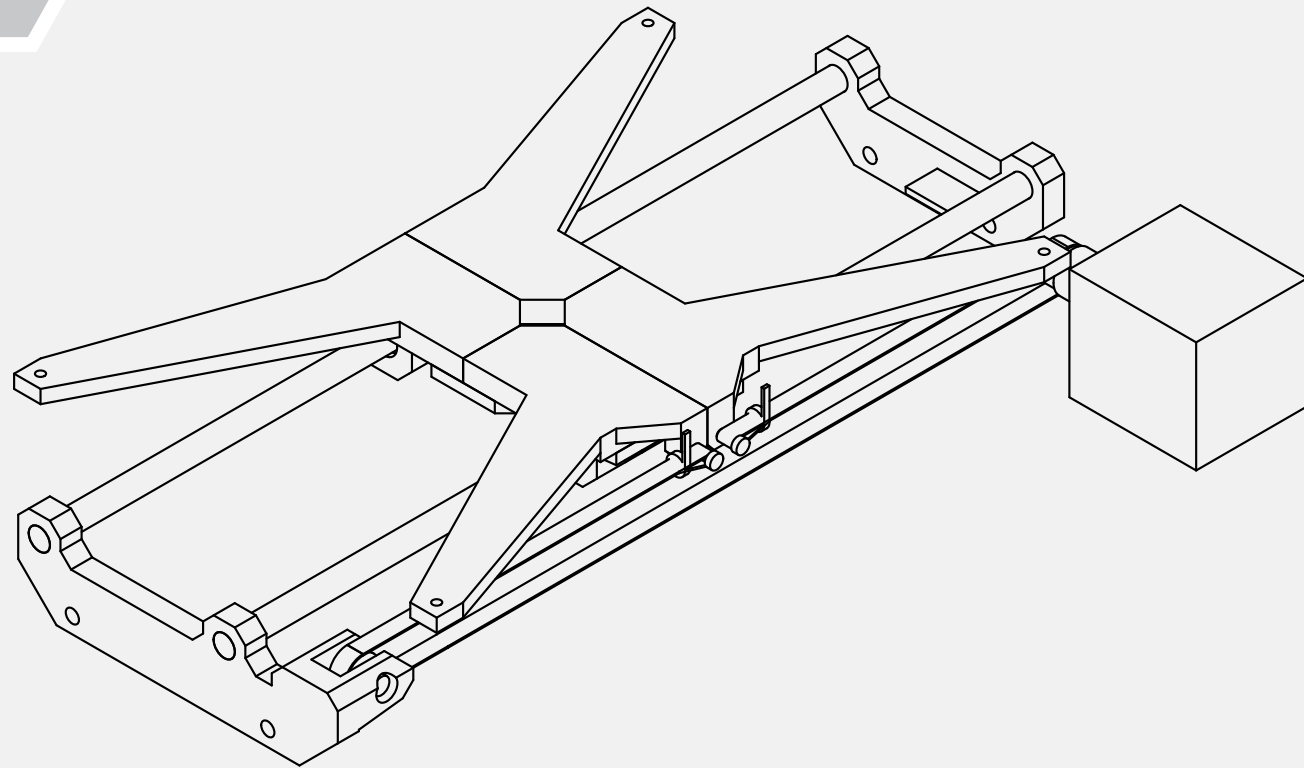

We will now complete the same procedure for the **Y axis**.

N/A

If not already cut, cut the belt to length so that it is long enough to loop around the motor, and opposite idler bearing with some extra length.

The belt will be mounted with the teeth facing inwards.

Take one end of the belt and loop it around one of the screws on the lower bed assembly.

4

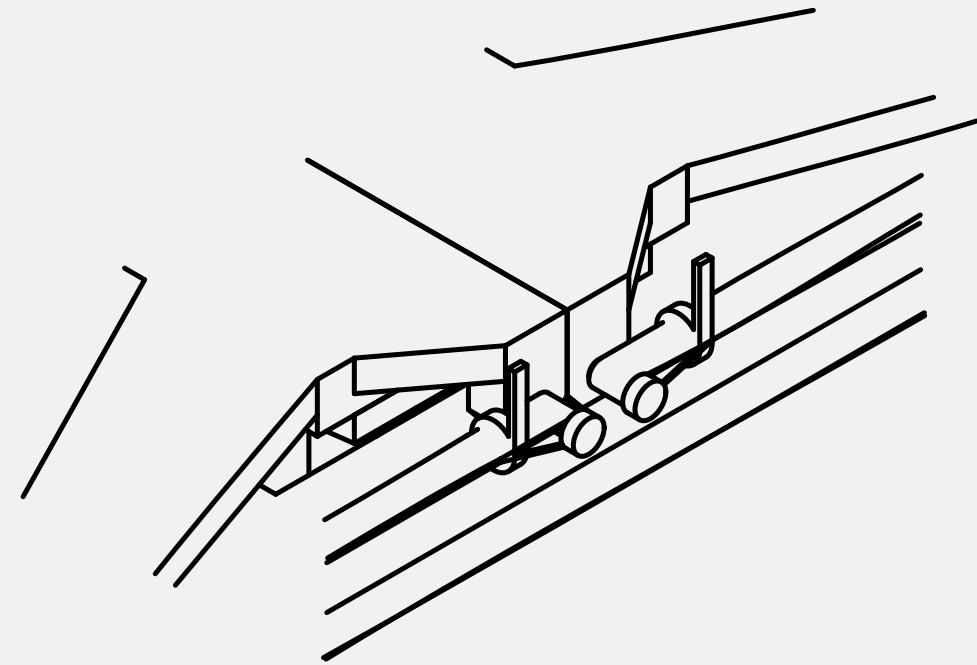

Secure this using a **cable tie** so that the belt teeth mesh together. Take the belt and loop it around the idler bearing and back around the pulley on the Y axis motor.

Your belt should be long enough to reach the remaining screw on the lower bed assembly.

While holding the extruder assembly in place, use a pair of pliers, or a second set of hands to pull the belt as tight as possible to remove any slack.

With the slack removed, secure the belt to the screw using the same method as before.

When complete, the belt should be tensioned and tight. If there is slack, you may loosen the 4 screws holding the motor in place and slide it backwards, away from the frame to tension the belt more.

Remember to tighten the motor mounts when complete.

1

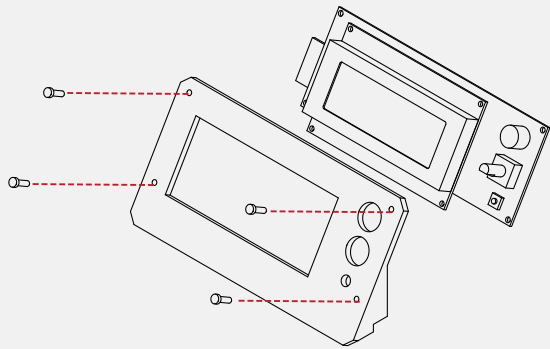

Locate the **LCD display** from your electronics kit, along with **4 M3 X 20 screws**, and the **LCD display mount** from your printed parts kit.

Remove the control nob from the LCD display by pulling straight up on it.

Using your **hex wrench**, insert the 4 screws into the LCD frame, and then into the LCD display.

X 4  M3 x 20

2

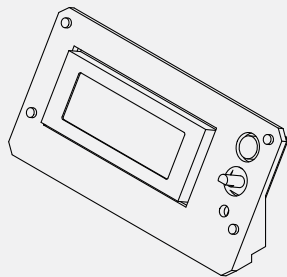

Use **4 M3 nuts** to secure the lcd display to the frame.

Take care to not distort the LCD frame or damage any components when installing the screws.

Re-attach the control nob onto the LCD display.

N/A

3

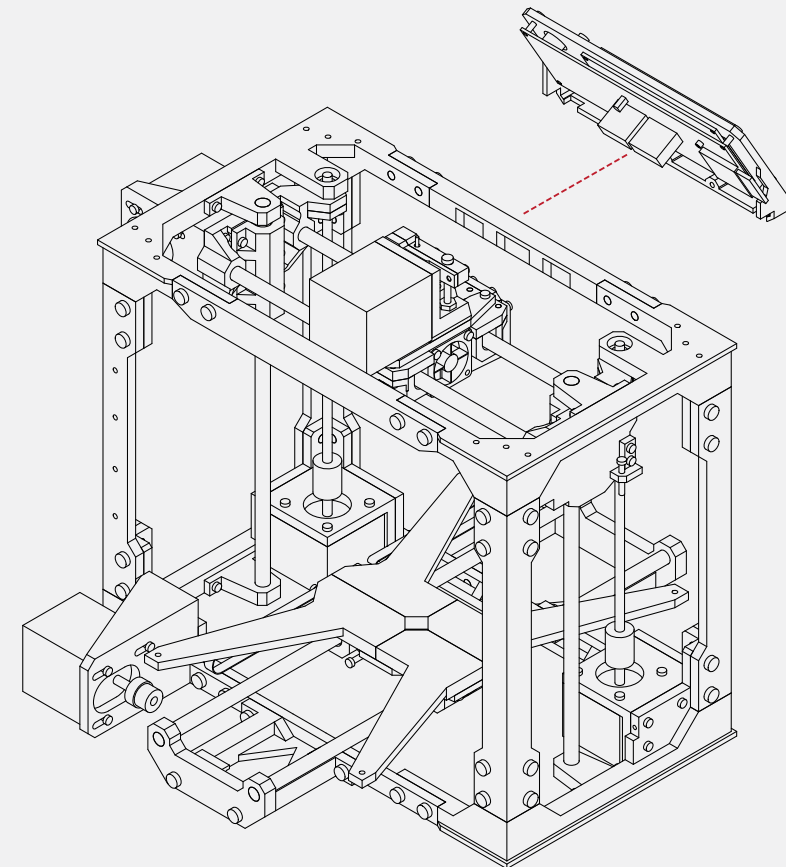

N/A

The LCD frame will affix to the front of the upper frame chassis.

Check to ensure that the frame and LCD panel will fit correctly before proceeding.

4

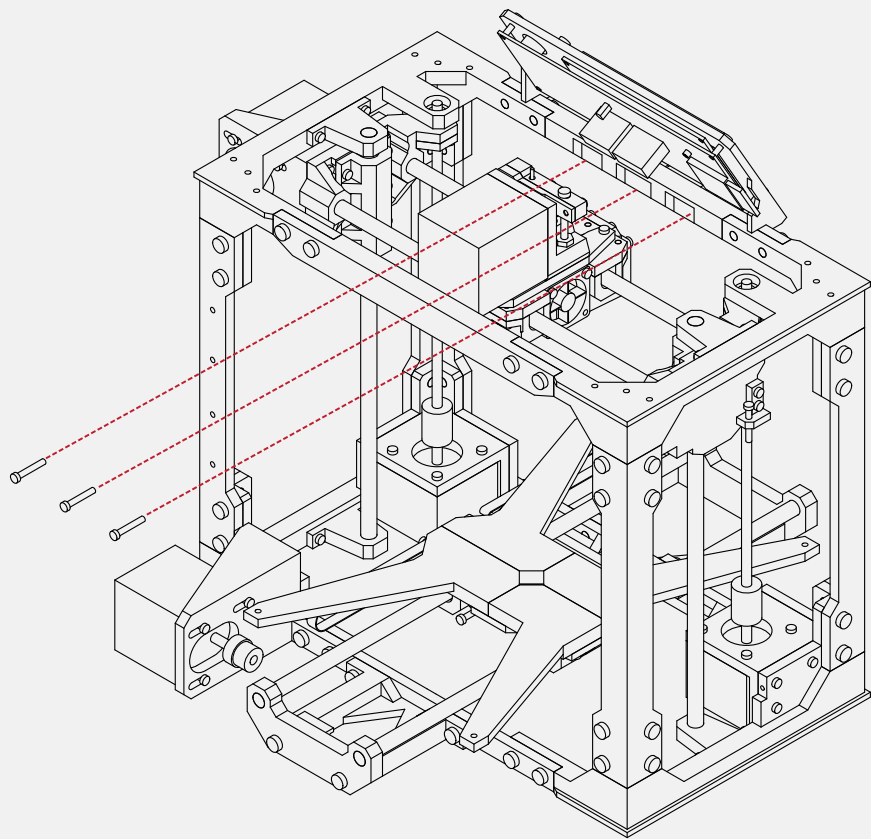

Locate 3 **M3 X 10 screws** from your hardware kit.

With the LCD assembly in place, use your **hex wrench** to insert the screws into the rear of the upper frame, and secure the LCD panel in place.

X 3



M3 x 10

5

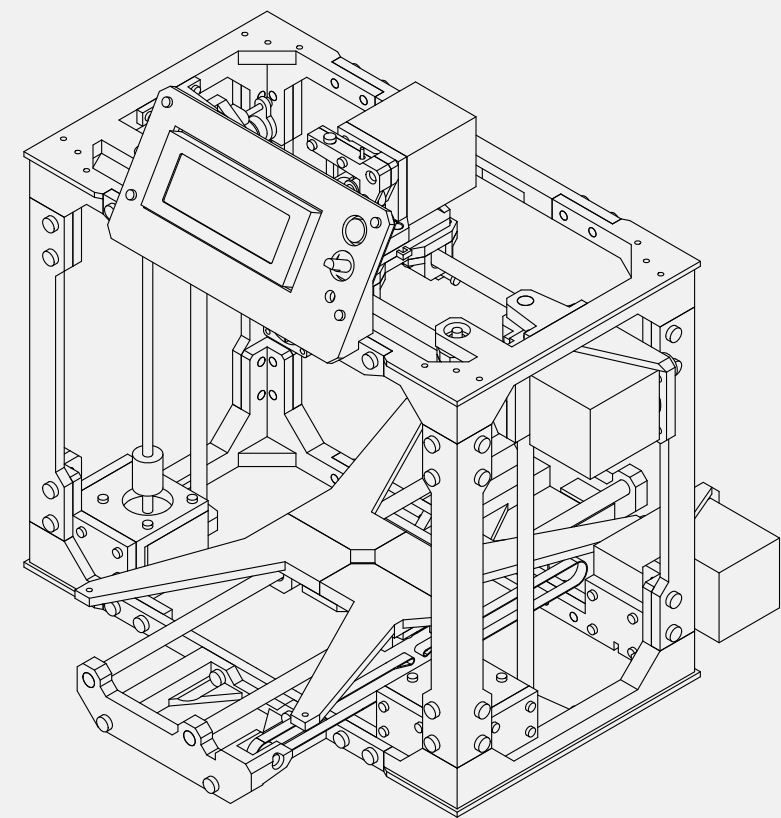

N/A

With the LCD assembly in place, ensure that it is secure and that it fits well.

Ensure all fasteners are tight.

6

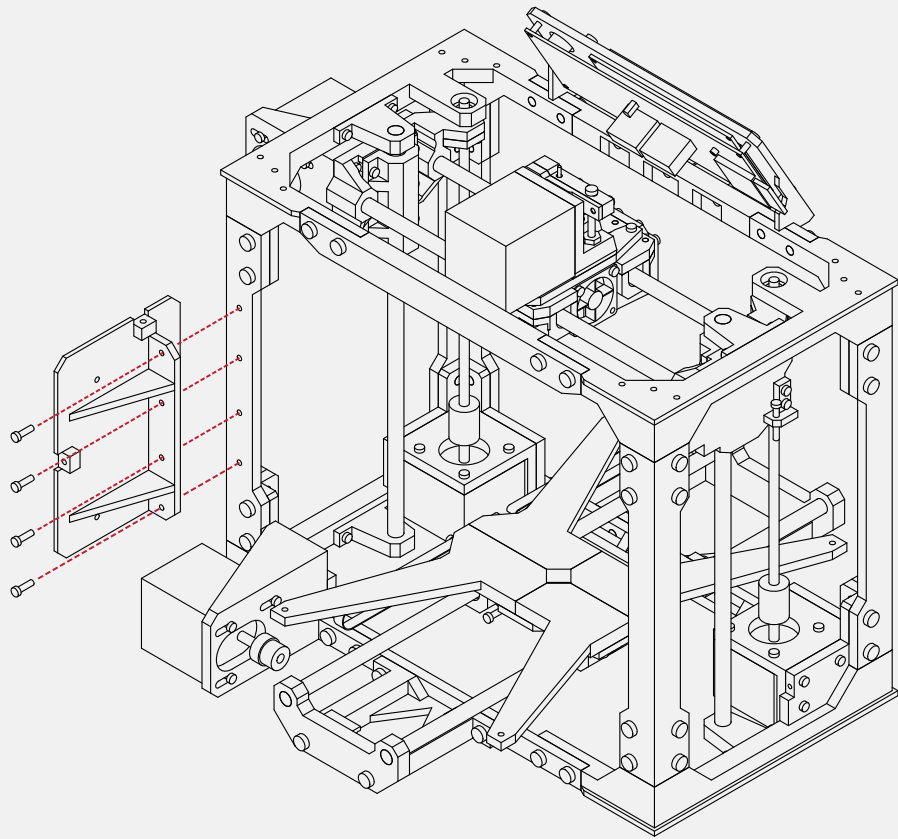

Locate the **Electronics backplate** from your printed parts kit, along with **4 M3 X 10 screws**.

X 4



Using your **hex wrench**, insert the screws into the backplate, and then secure the backplate to the rear upright frame.

7

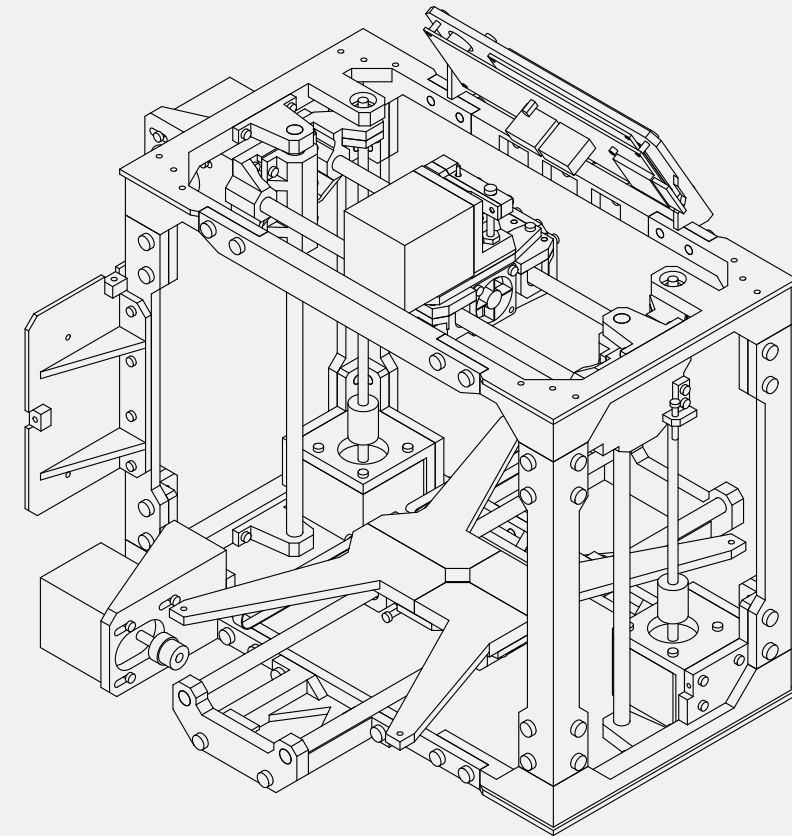

N/A

With the backplate in place, ensure that the plate is tight to the frame, and that all fasteners are secure.

8

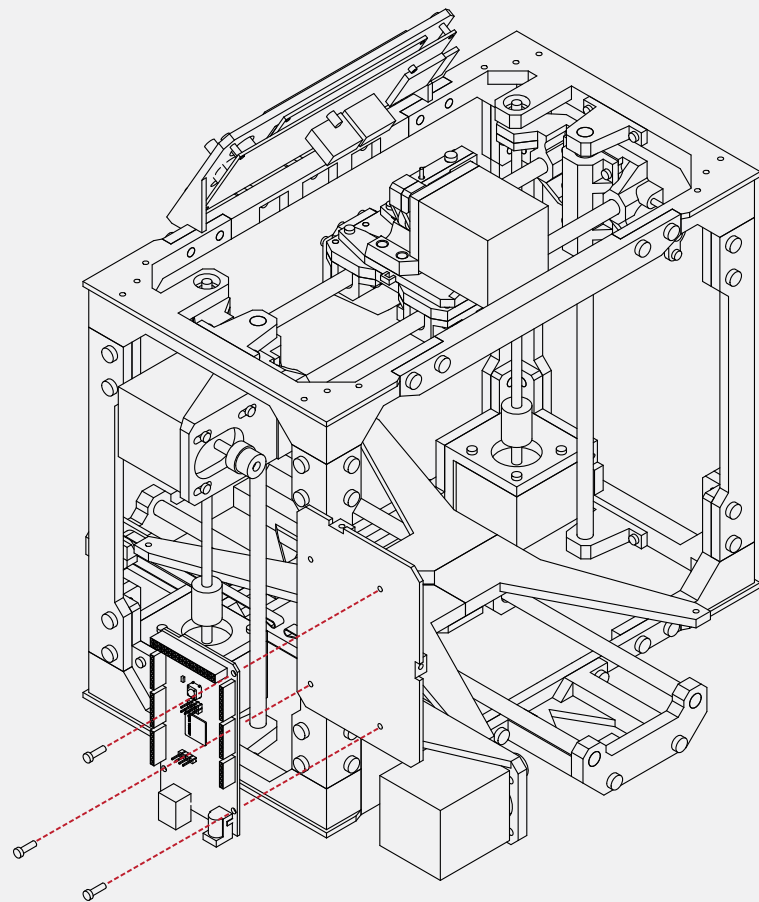

Locate the **Arduino Mega** from your electronics kit.

This is easily identified by its blue colour board.

Using **3 M3 X 10 screws**, attach the Arduino to the electronics backplate.

Take care to ensure that the Arduino is not bent or mis-aligned.

The board does not need to be absolutely tight, just secure.

X 3



N/A

9

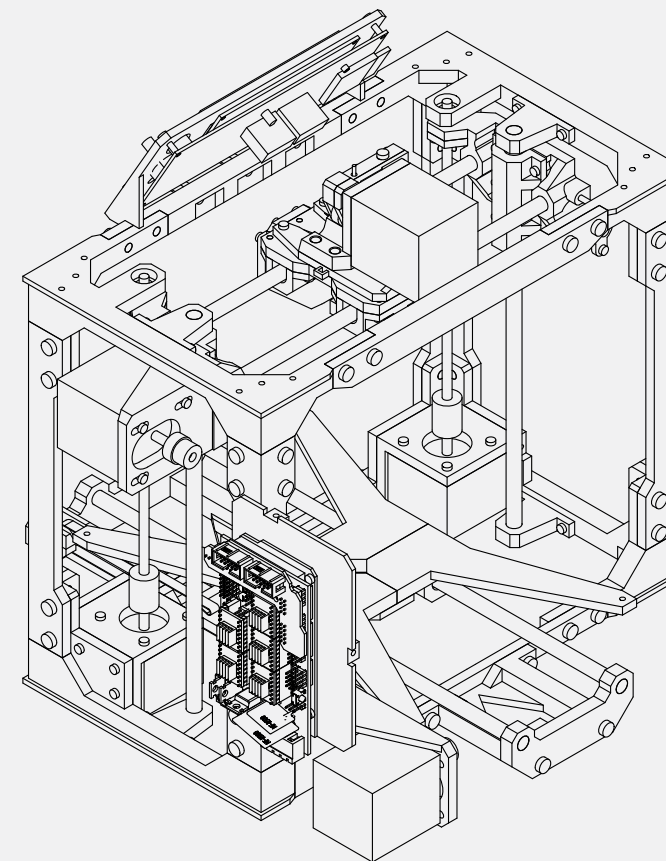

Gather the **RAMPS 1.4** electronics board from your hardware kit.

Carefully insert it onto the Arduino board we attached in the previous steps.

Take care to ensure that all of the pins line up with their respective sockets, and that the board is fully seated.

1

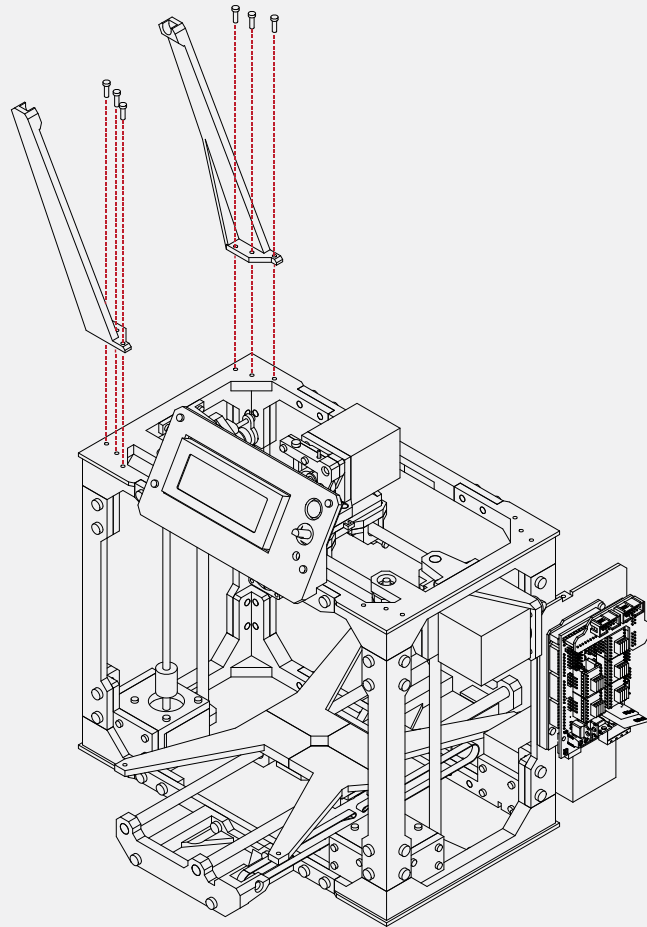

Locate the **Spool holder mounts** from your printed parts kit, along with **6 M3 X 10 screws**.

X 6



The spool holder can be mounted on either side of the top frame.

Using your hex wrench, insert the screws into the spool holder mounts, and then into the top of frame.

2

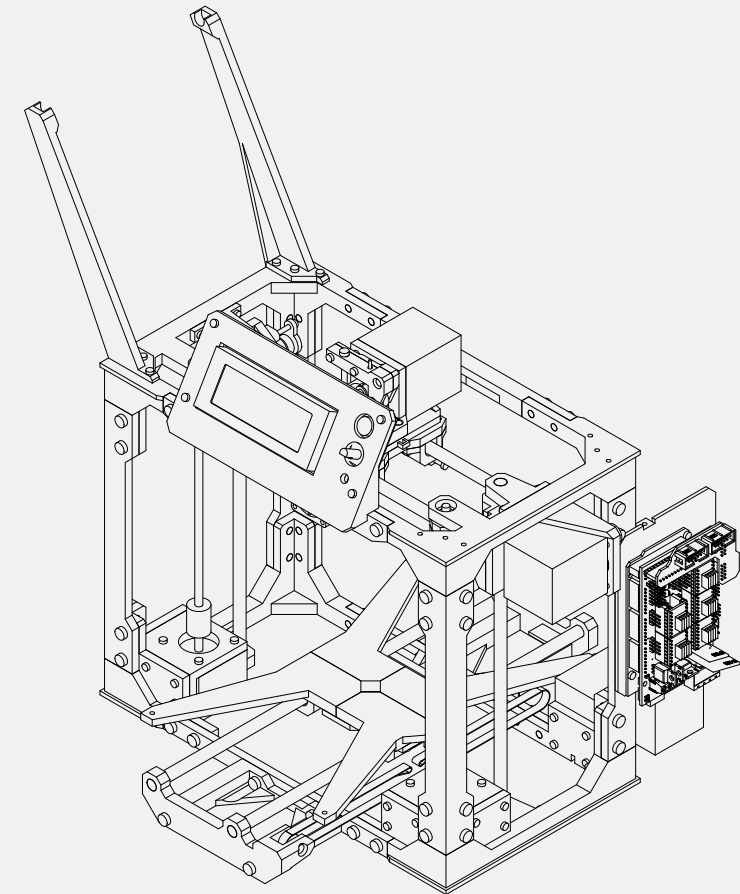

N/A

With the spool holder installed, you can use the remaining short linear rod to hold the filament spool in place.

10

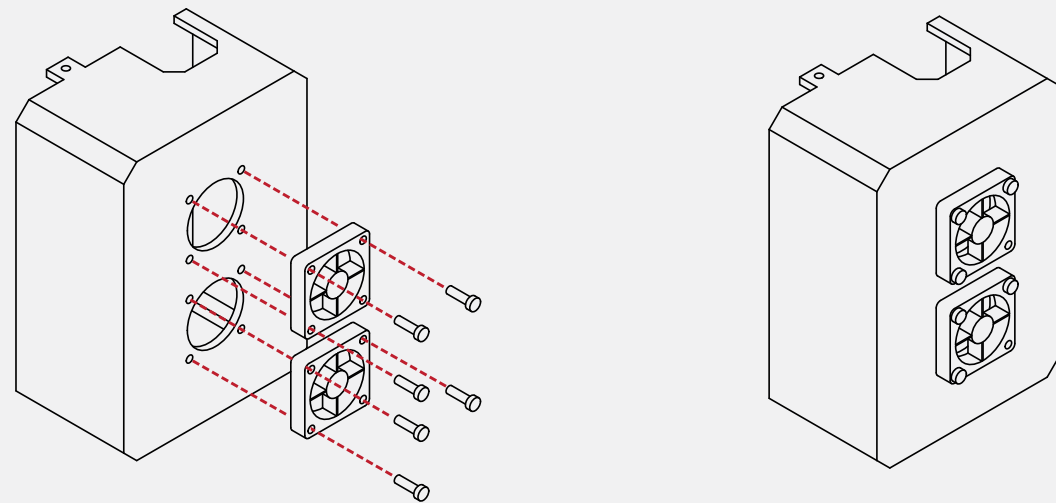

Locate the **Electronics enclosure** from your printed parts kit, along with **2 30mm fans**, and **6 M3 X 16 screws**.

X 6



Using your hex wrench, attach the fans to the outside of the enclosure.

Feed the fan wires through the remaining screw hole in the enclosure.

11

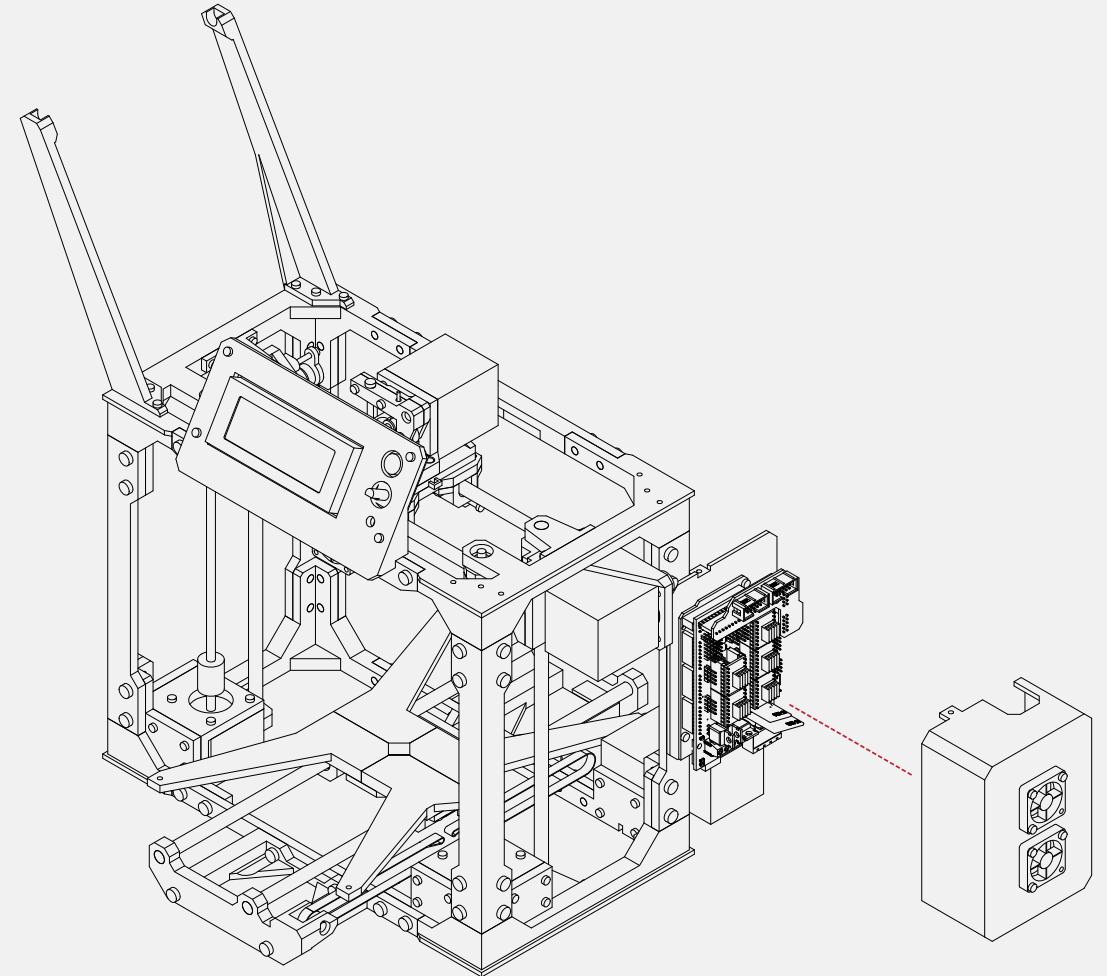

N/A

Check the fitment of the enclosure to the electronics back plate.

The tabs on the enclosure should align and fit with the back plate.

You may need to use a small exacto knife or file to trim the tabs if the enclosure does not fit correctly.

12

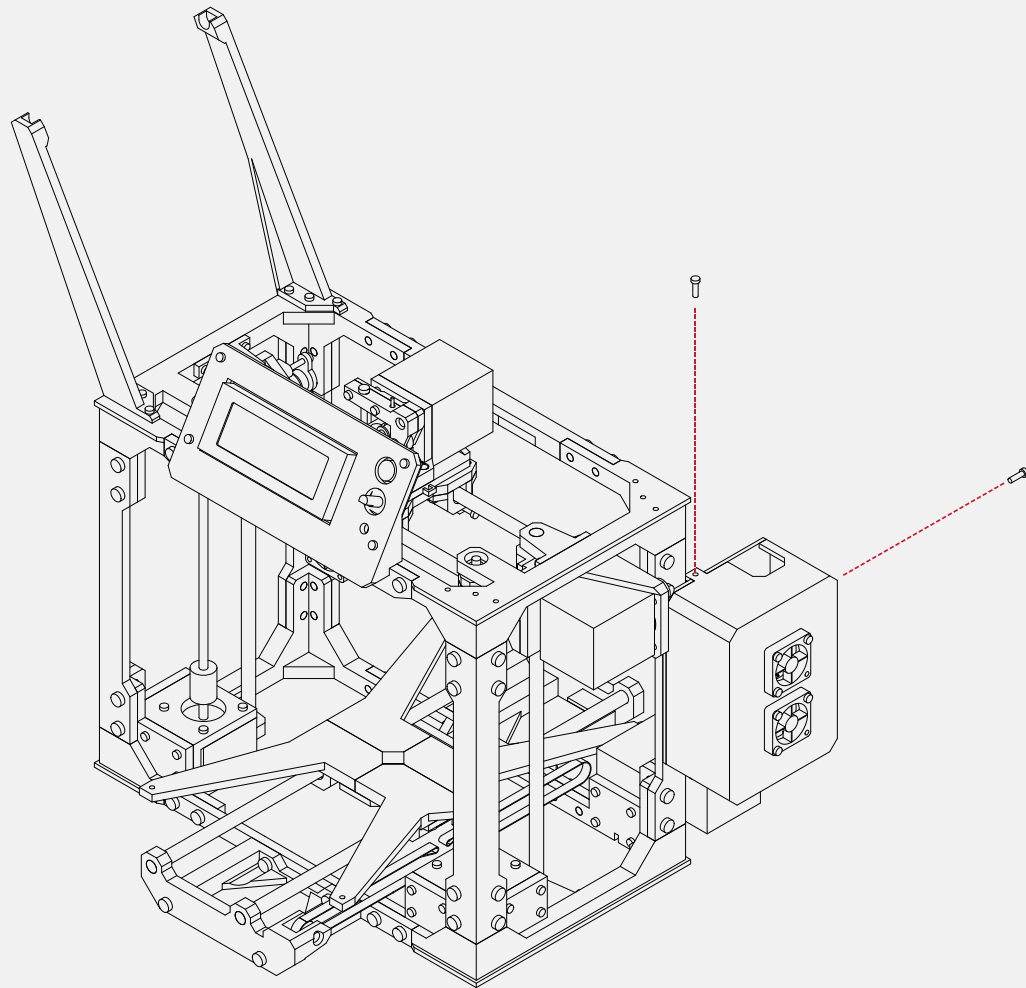

With the enclosure in place, use **2 M3 X 10 screws** to secure the enclosure.

X 2



13

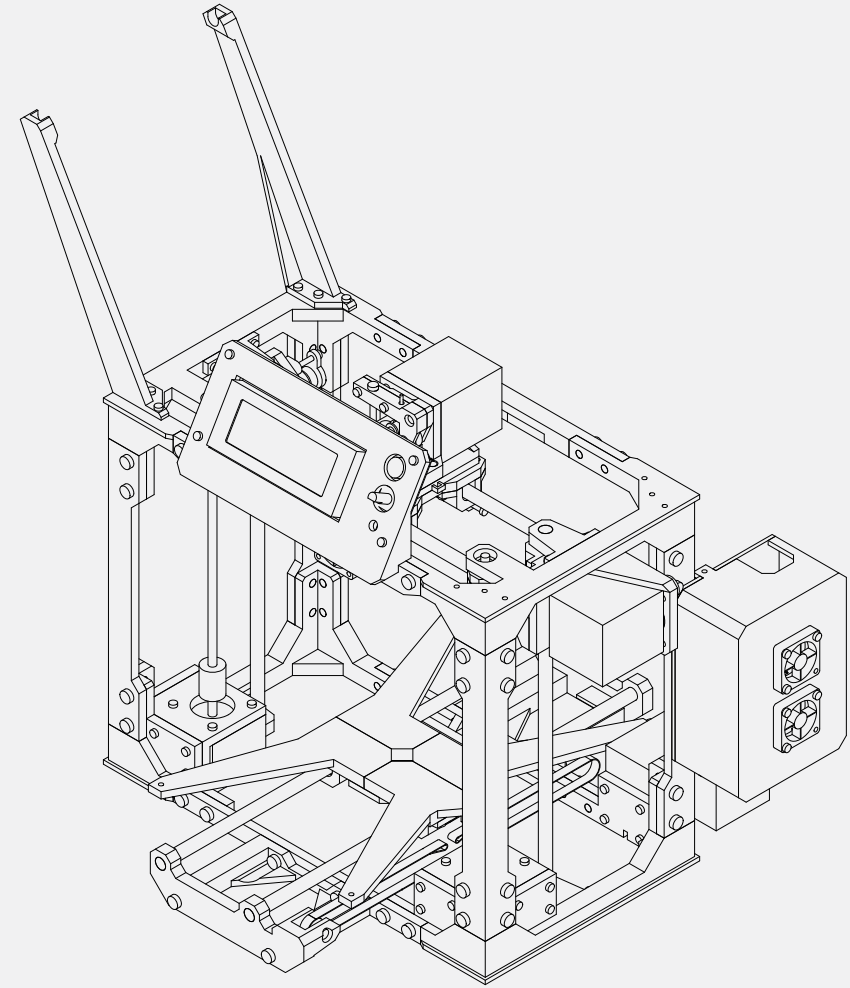

N/A

The electronics enclosure is now complete.

However, for the next steps we will need to remove the cover.

Refer to these steps to remove and reinstall the enclosure when completed.

1

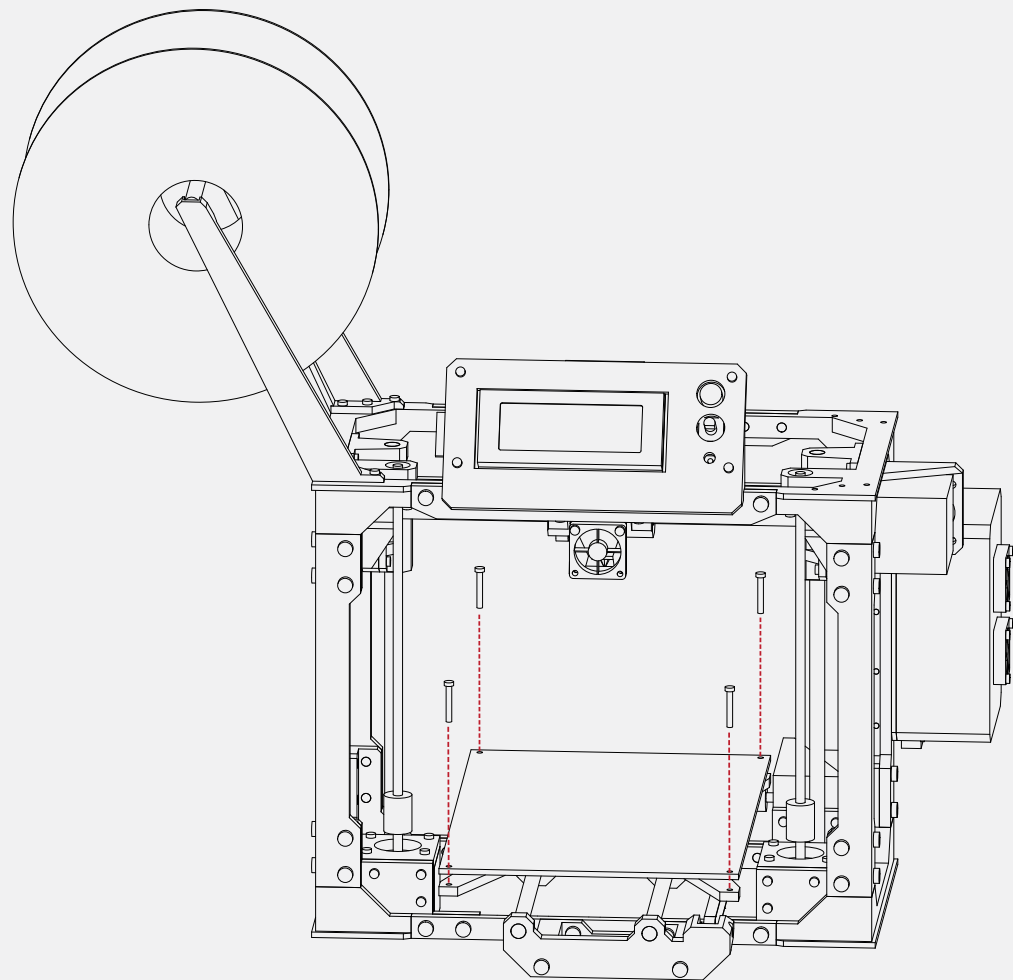

Locate the **upper bed** from the remaining parts kit, along with **4 compression springs**, and **4 M3 X 20 screws**.

X 4



Insert the screws into the upper bed, and place the compression springs onto the screws.

Take the assembly and attach it to the lower bed.

2

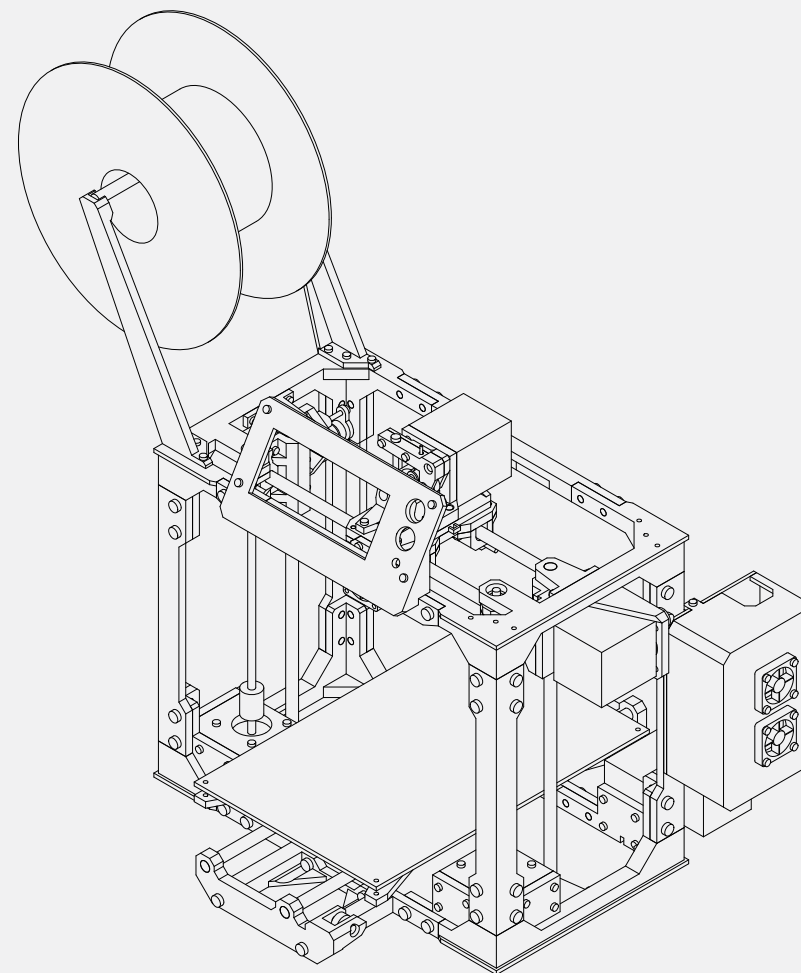

N/A

With the bed in place, the compression springs will allow the bed to be leveled and adjusted.

This is useful for when we set up your printer for its first print.

For now, adjust the screws so that all 4 springs appear equal.

1

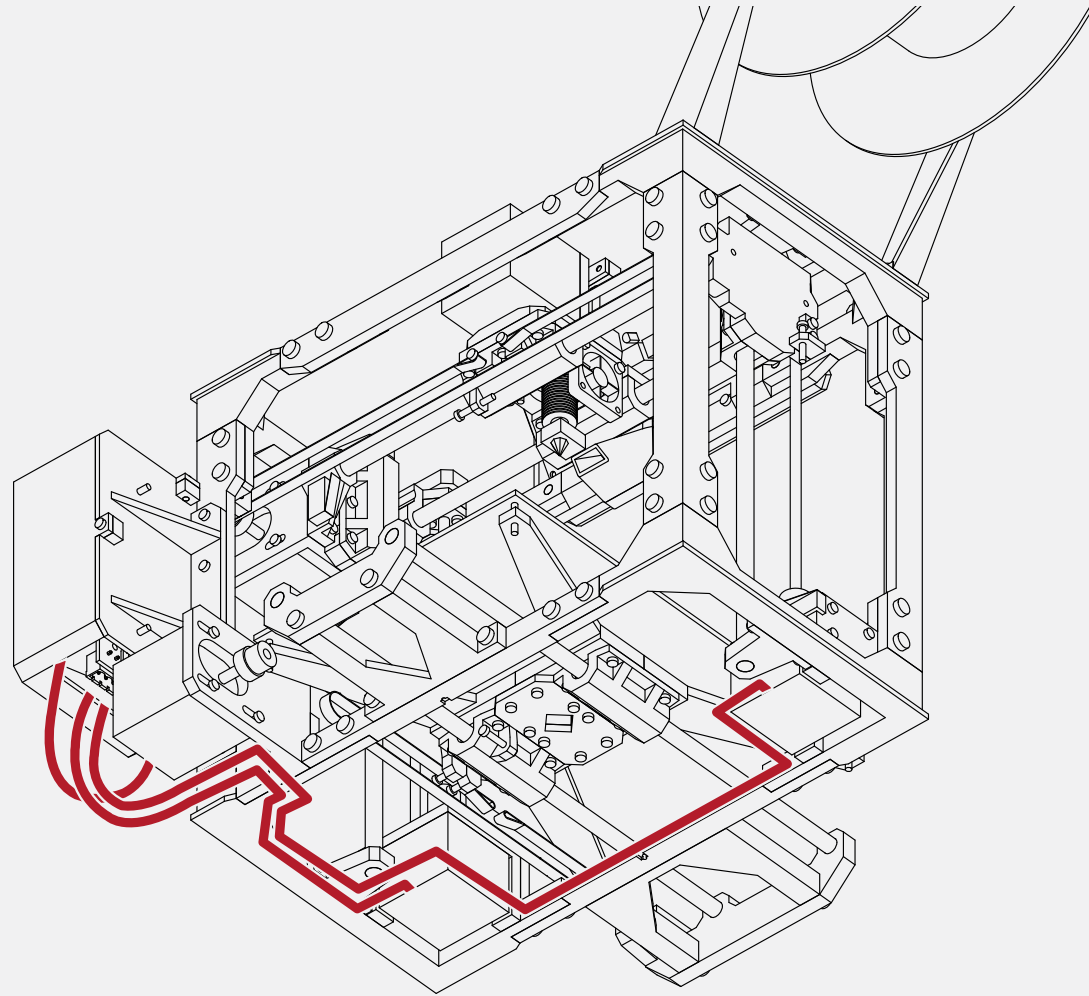

From the wiring kit, gather **3 of the wire bundles for the stepper motors.**

N/A

Connect the wires to the stepper motors. Take note that the connections are keyed and will only fit in one direction.

Route the wires similar to the diagram above.

There are several small cut-outs in the frame and areas where you may use a cable tie to secure the wires.

2

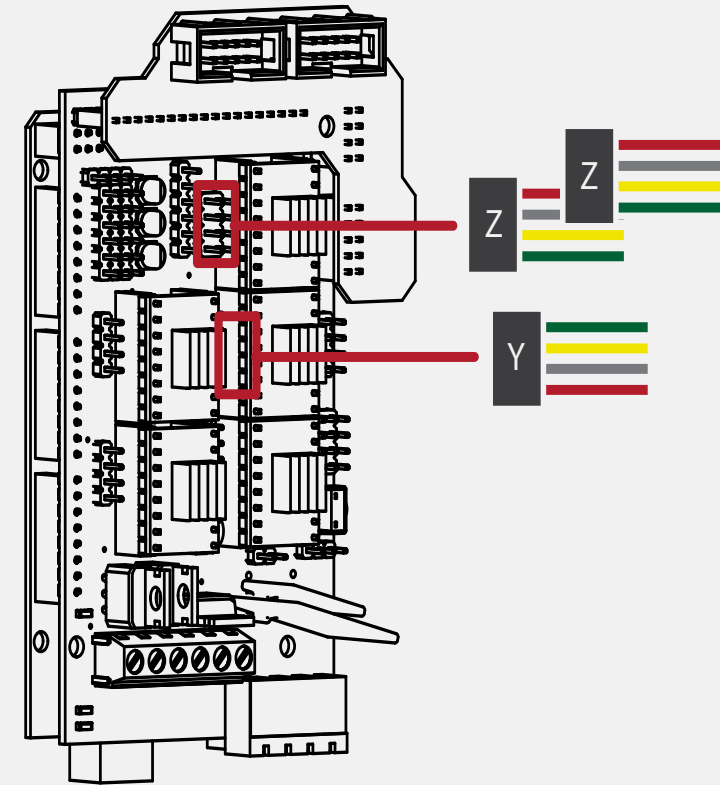

N/A

Connecting the stepper motors to the RAMPS is a very simple process.

Take one of the wire leads from the motors and attach it to the driver header pins noted above.

Note the orientation of the wire colours and how they attach to the headers.

While no damage will occur if the wires are backwards, the motor will simply run in reverse of its intended direction.

3

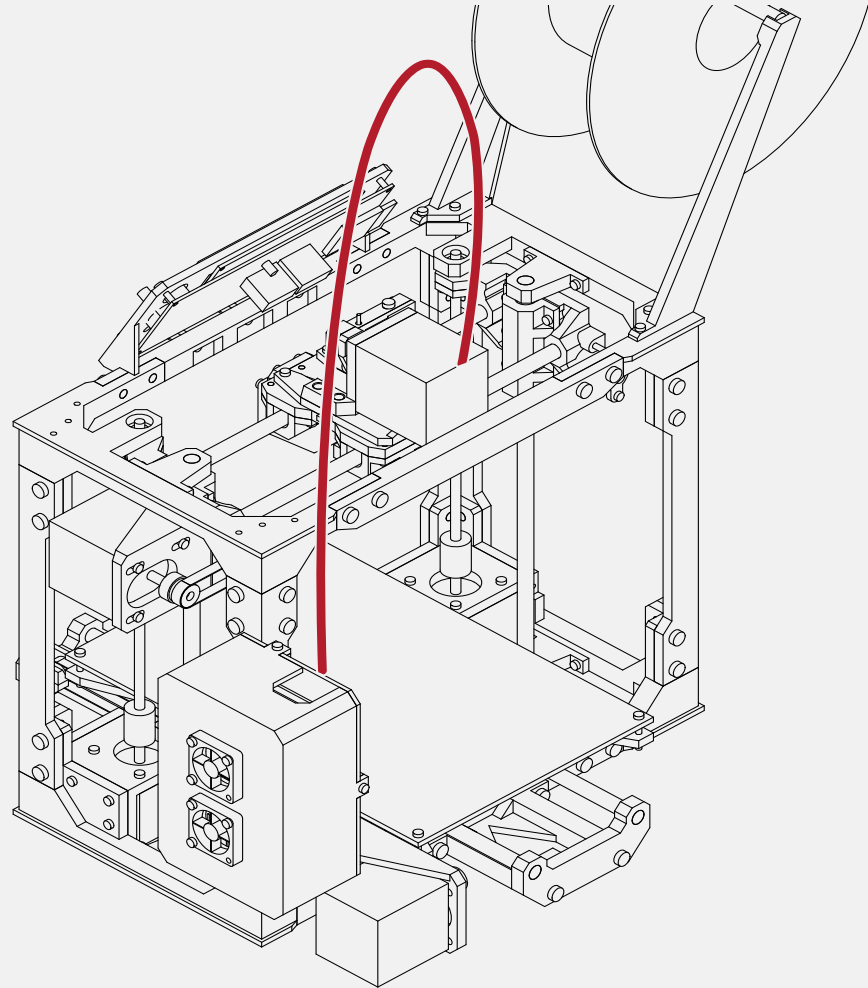

Route the stepper wires for the extruder up and over the top of the frame. Give the wire enough slack so that the extruder can freely move to each extent of the frame.

N/A

4

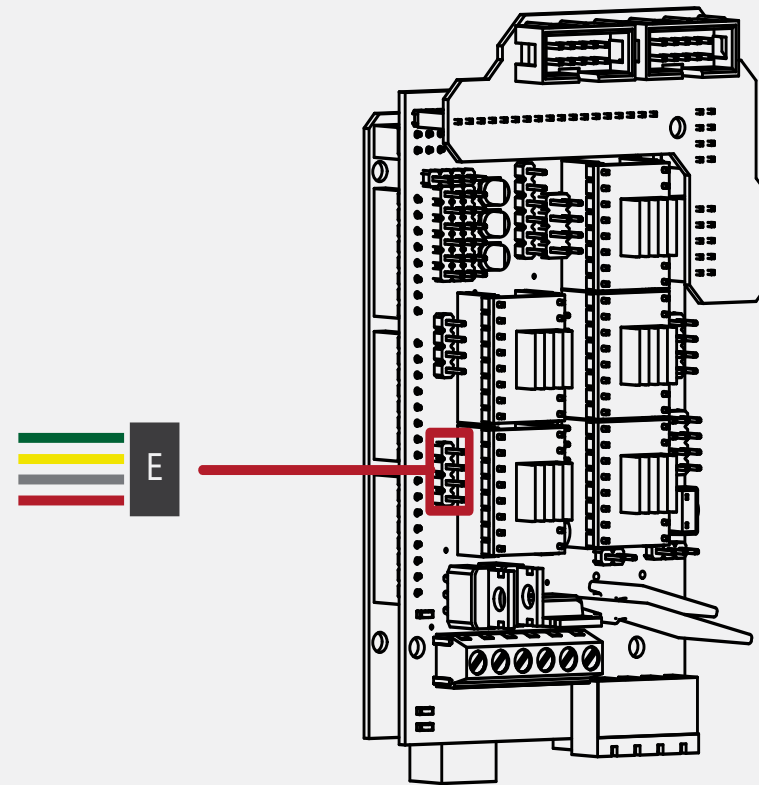

N/A

Like the previous step, attach the extruder connector to the header pins outlined above.

5

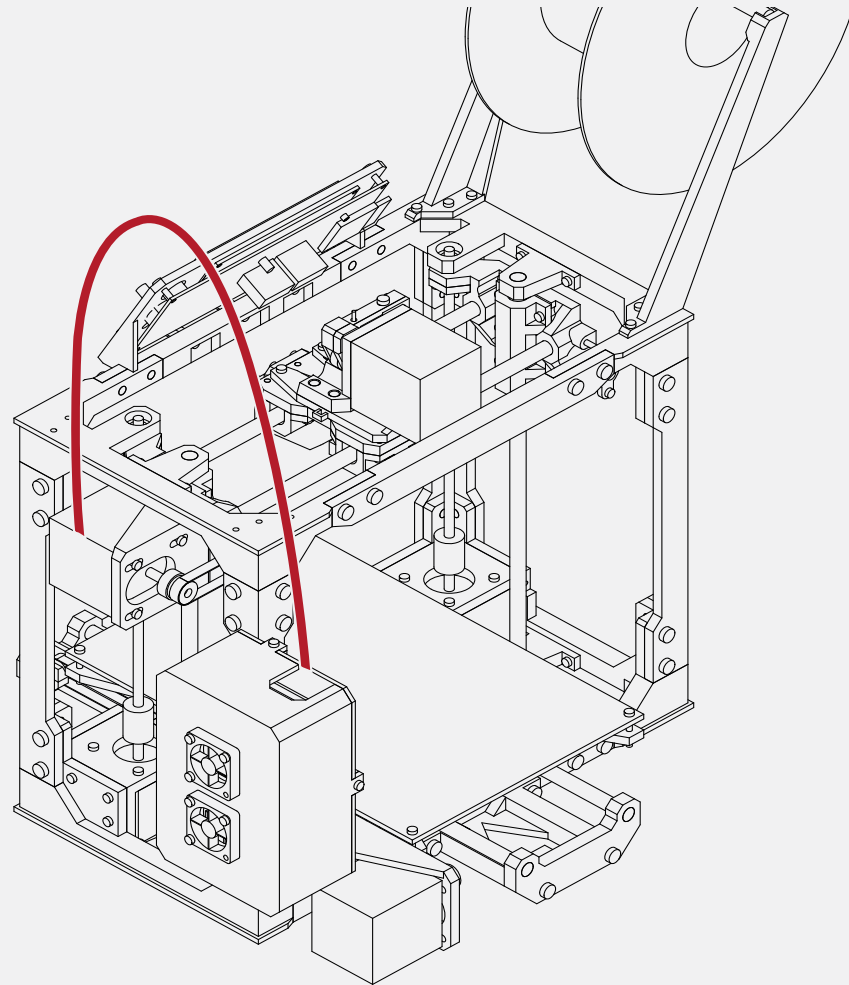

Route the X stepper motor wires over the side of the frame and into the electronics enclosure.

N/A

Ensure that there is enough slack in the wires so that the X axis does not bind at either extent.

6

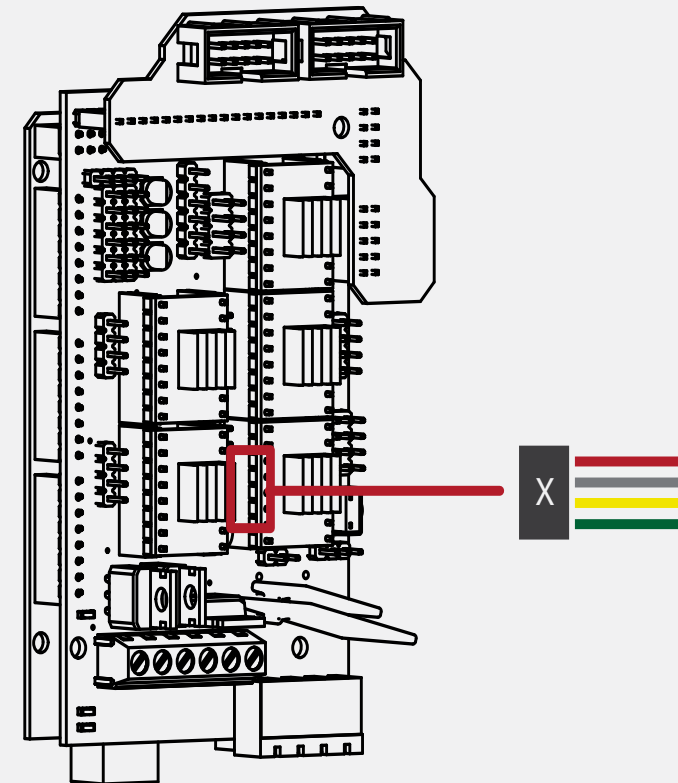

N/A

Connect the X axis stepper wire to the header pin. Note the orientation of the connector.

5

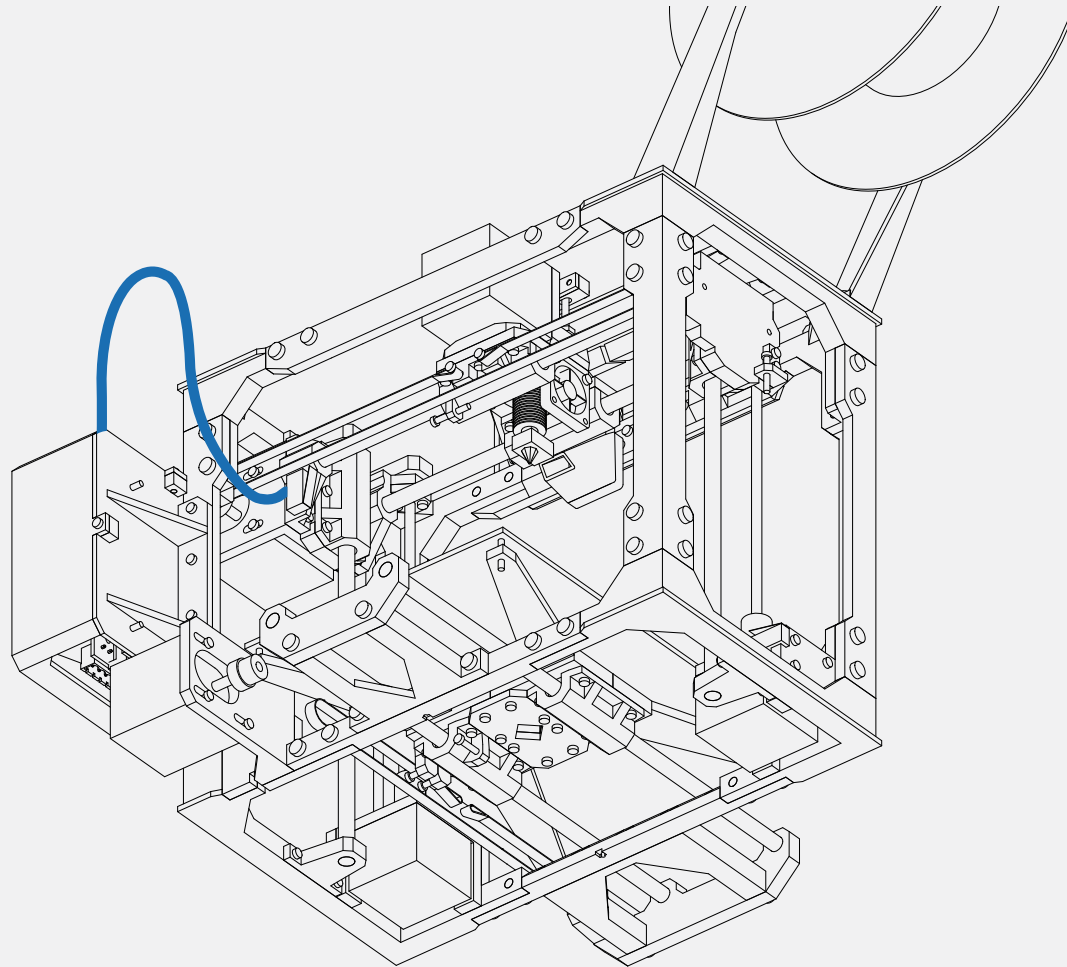

Locate the **End-stops** from your electronics kit.

N/A

The X axis end-stop locates the minimum starting position for the extruder assembly.

Using a hot glue gun to secure the ed stop, attach the end stop to the flang on the X axis carrier.

Align it so that trigger is in line with the long end stop screw that we attached to the extruder assembly.

6

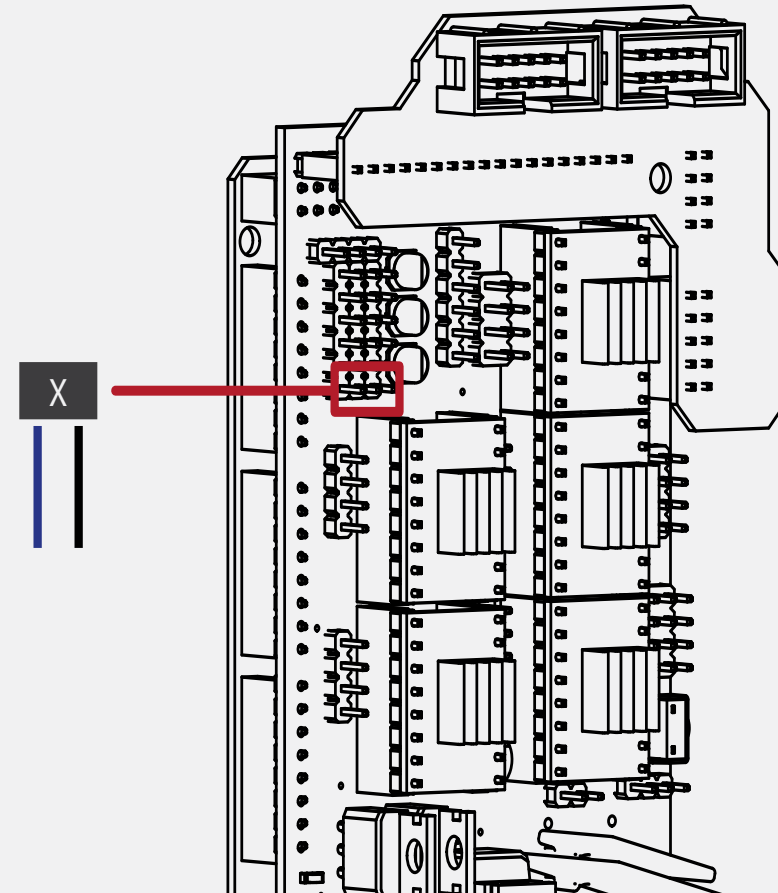

N/A

Connect the X end stop according to the diagram above. The end stop is a 2 wire connector.

The end stop connector, and RAMPS board may have a 3 pin or 4 pin connector, don't worry about this, simply ensure that both wired pins on the end stop connector are attached to pins on the RAMPS board.

7

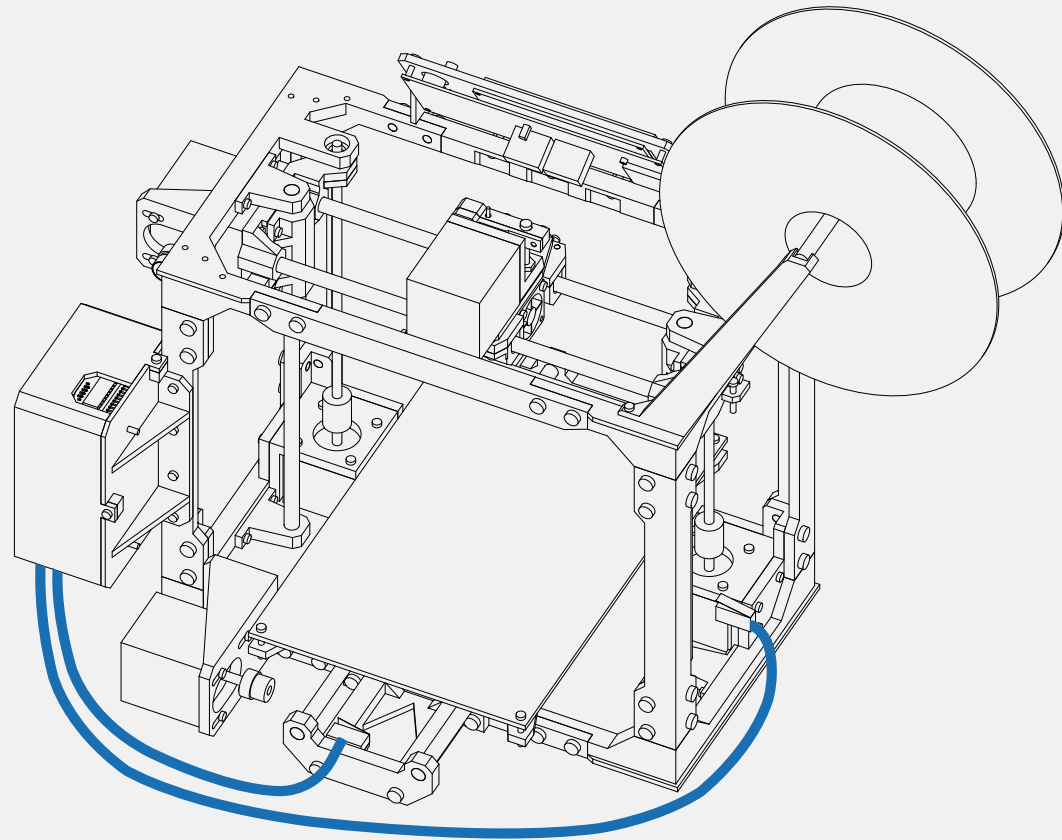

Locate the **End-stops** from your electronics kit.

N/A

Attach the Y axis end stop to the small shelf at the rear of the Y axis.

Attach the Z end stop to the small shelf on the side of the frame.

In both instances, ensure that the triggers are aligned with the trigger screws on both axis. We will be fine tuning these screws later in the guide.

8

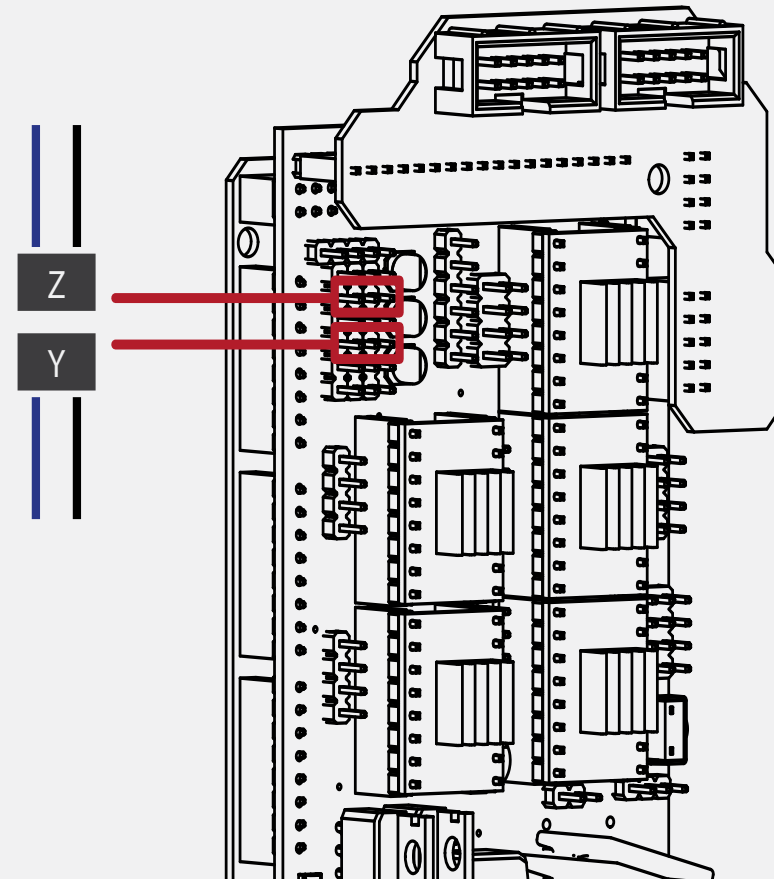

N/A

Connect the Y and Z end stop according to the diagram above. The end stop is a 2 wire connector.

The end stop connector, and RAMPS board may have a 3 pin or 4 pin connector, don't worry about this, simply ensure that both wired pins on the end stop connector are attached to pins on the RAMPS board.

9

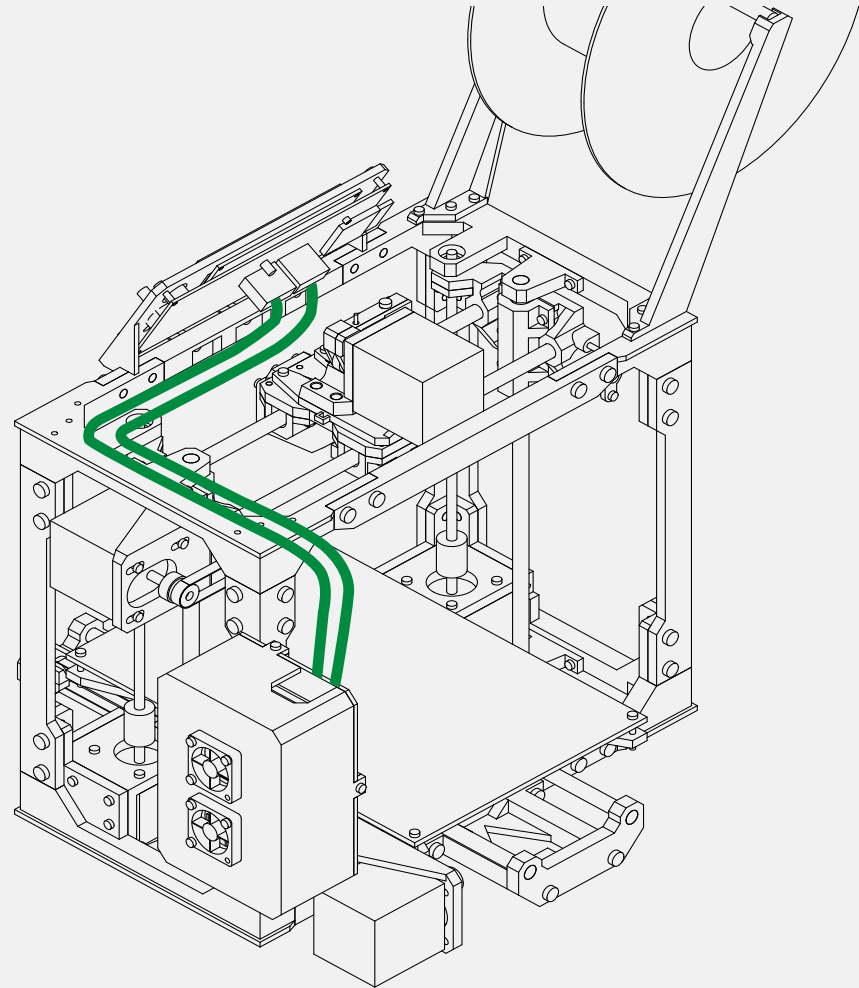

Locate the **LCD ribbon cables** from your electronics kit.

Attach both cables to the rear of the LCD assembly.

Use cable ties to secure the ribbon cables to the frame.

N/A

10

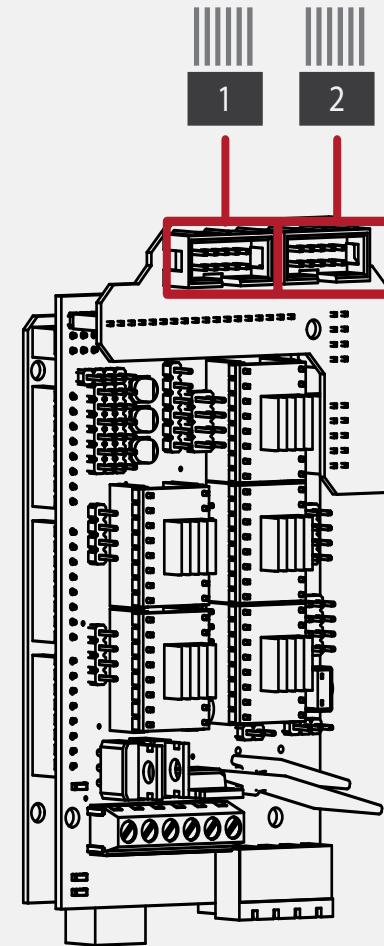

N/A

Attach the LCD ribbon cables to the top of the RAMPS electronics.

The connectors are keyed, and will only connect in a single direction.

11

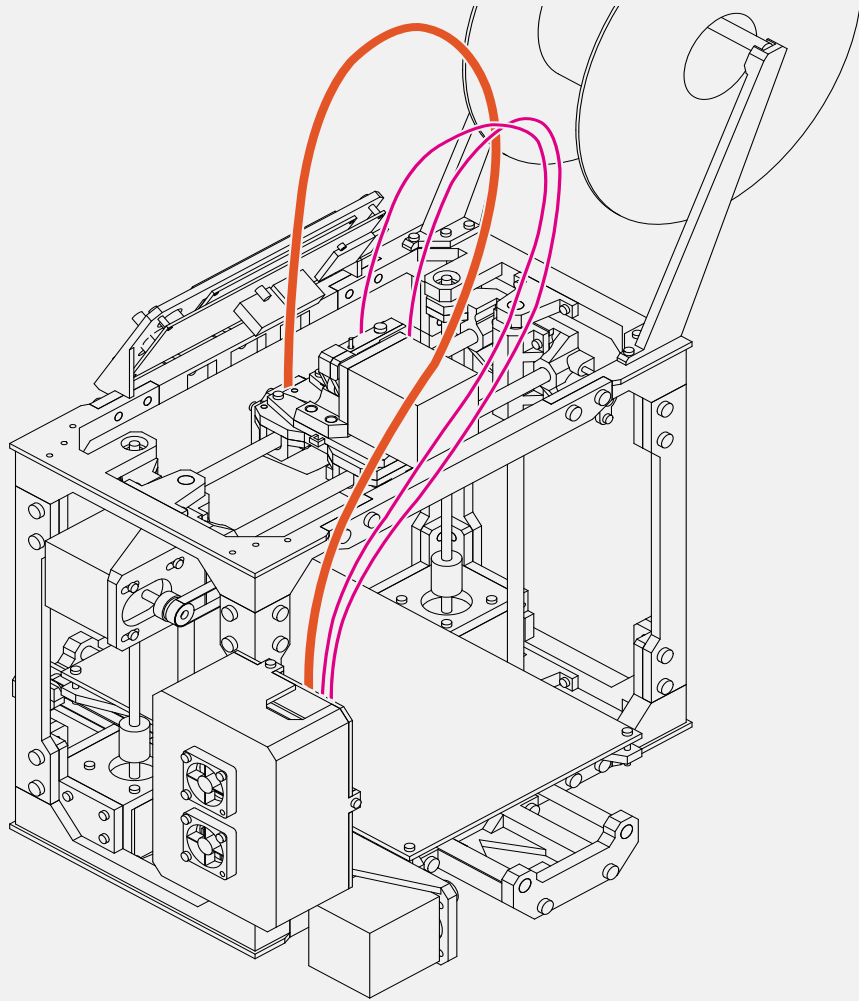

Gather the **hot end heater cartridge** and route it over the top of the frame and into the extruder assembly.

N/A

Route the cooling fan and hot end fan wires over the top of the frame and into the electronics enclosure.

12

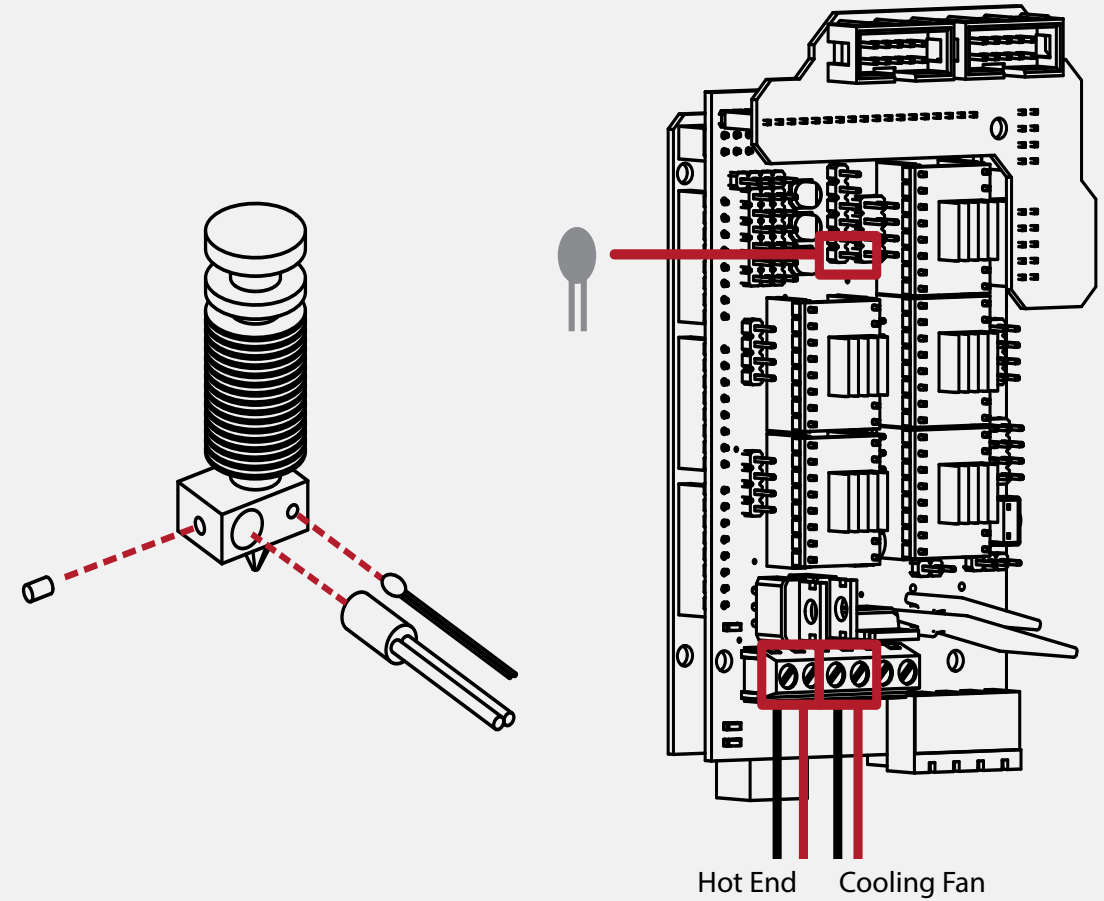

Please refer to your hot-end's instructions for correct assembly, however the basics are, insert the heater cartridge into the heater block and secure the cartridge with the small set screw.

Insert the thermistor into the small opening on the heater block. Use a cable tie to hold both wire sets together.

The connectors used for the hot end and cooling fan are slightly different from the other.

Attach the heater cartridge wiring to the connectors labeled D10. Attach the Print Cooling fan to the D8 connector.

Connect the thermistor to the header pins noted above.

13

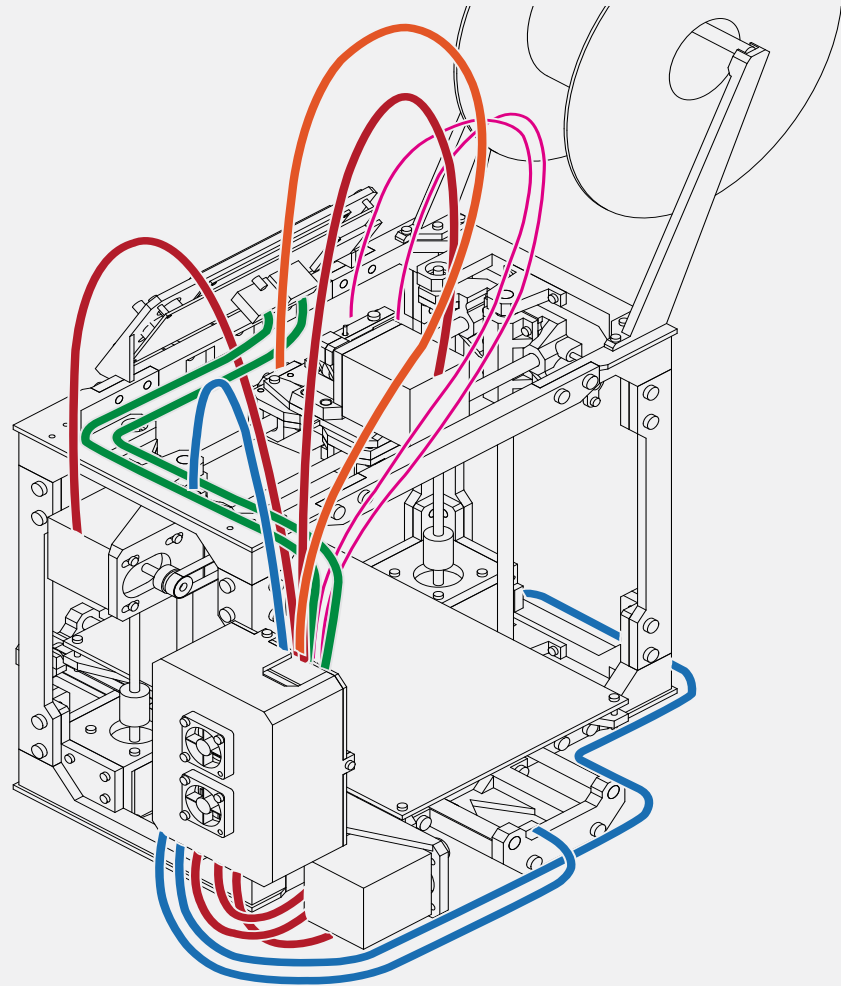

Take the final pair of wires belonging to the Hot End fan and route them over the top of the frame and into the electronics enclosure.

N/A

With the wiring mostly complete, use cable ties to neatly secure and bundle the wires.

Ensure that no wires are caught on any portion of the frame, and that all wires are long enough to reach the full extents of the printer's motions.

14

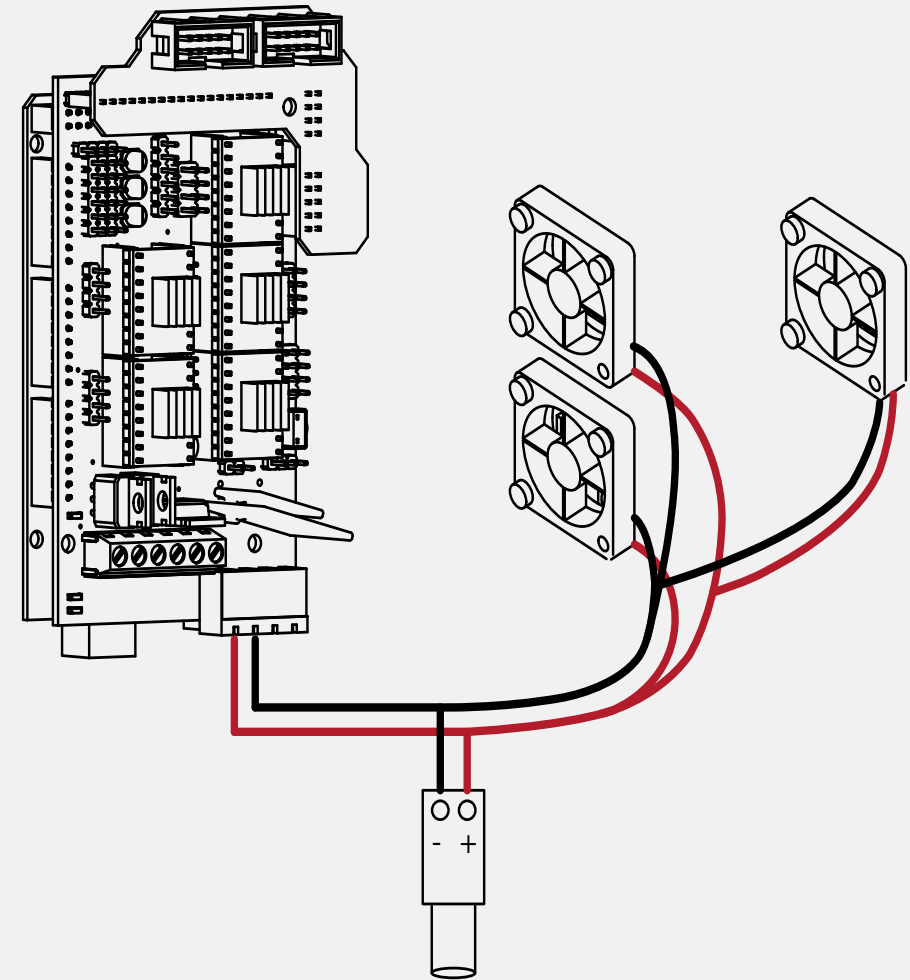

The last connection is to connect the electronics enclosure fans to that of the main power supply.

Wire the fans in parallel to the barrel connector, as well as the Hot end fan.

Connect a pair of wires from the barrel connector to that of the 12V input on the RAMPS board.

Note the polarity of the wires matches the correct polarity of the barrel connector. With the wiring complete, connect the power supply to the barrel connector and check that there is a green LED on the RAMPS board.

The electronics enclosure fans, and Hot End fan should also be operational.

Once you've verified that everything is functional, re-attach the enclosure. Your printer is now complete.

SECTION

F

6.1 Appendix

136

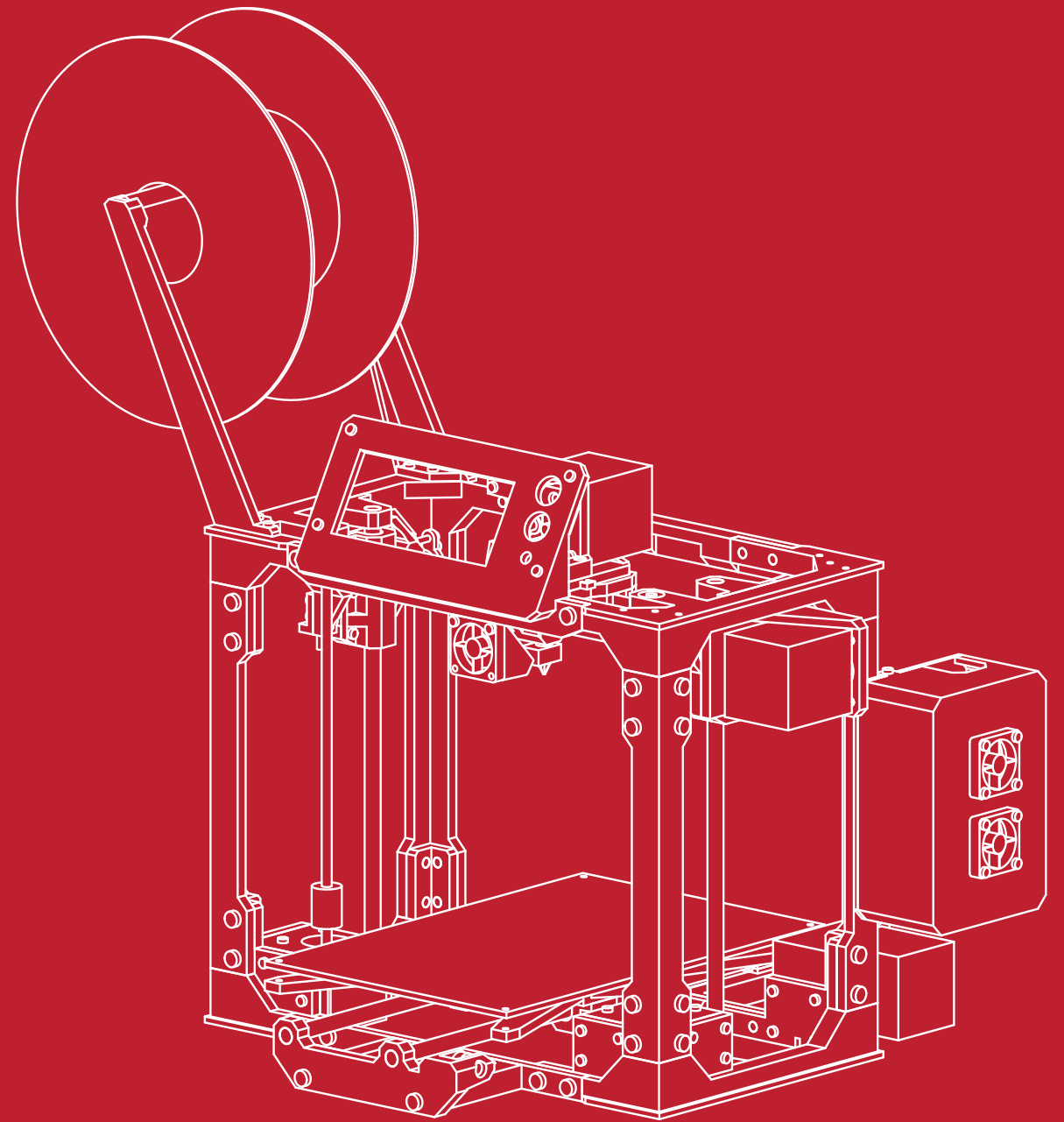

Congratulations! You've successfully completed the hardest portion of the build! Pat yourself on the back and marvel at the amazing piece of engineering you've just assembled! We're almost ready to begin printing, but before we do, there's a few more items we will need to cover:

Leveling Your Print Bed:

For detailed instructions on this procedure, please refer to the guides and instructions on www.maplemakermedia.com. The following is a brief overview of the procedure.

Grab a roll of 3M Blue painters tape, and apply a layer of tape to the print bed surface. Be sure to not overlap the edges, a small gap between each strip will suffice. Unscrew the Z height screw on the side of the X axis assembly. Level the bed by adjusting the 4 screws at the corners until it appears to be roughly level.

Move the extruder to the front corner of the bed, and lower the print head towards the bed by rotating the Z threaded rods. We want to bring the hot end close but not touching the print bed. Grab a small scrap of paper. Slide the paper between the hot end nozzle and the bed, and lower the extruder until the nozzle touches the paper.

You should feel some resistance when moving the paper under the nozzle. This is the ideal height for our first layer. If the bed is too high or too low, adjust the height of the bed by adjusting the bed screws until the distance is right. Repeat this step for each corner of the bed. Your bed should now be roughly level.

Return to the Z height screw. The screw should not be contacting the limit switch below it. Slowly and carefully screw in the adjustment screw until it contacts the switch. Continue to adjust the screw until you hear an audible click of the switch being triggered. Congrats, your Z height is now set!

Leveling Your Print Bed:

For detailed instructions on this procedure, please refer to the guides and instructions on www.maplemakermedia.com. You will need a computer, USB cable and your printer to complete this step.

Software Suite:

For detailed instructions on this procedure, please refer to the guides and instructions on www.maplemakermedia.com. The following is a brief overview of the procedure. Throughout the next steps, we will be using the Arduino SDK, as well as the Cura slicing engine and printer control.

The Arduino SDK can be downloaded from: <http://www.arduino.cc/en/Main/Software>

Cura may be downloaded from: <http://wiki.ultimaker.com/Cura>

A Note on Self Sourcing Builders:

For those of who wish to source their own components outside of the available kits, we want to clarify a few steps that must be taken.

You will need to cut your linear rods to length, the lengths are as follows. You will need to cut 2 of each:

X Axis: 250mm

Y Axis: 310mm

Z Axis: 250mm

Z Axis Threaded rod: 190mm

You will need to solder the wire connections to the limit switches. These are wired in the normally open (NO) configuration. Refer to the markings on the limit switch for the correct orientation. This is typically the outer pins, with the centre third pin not being used.

Additional information is available through www.maplemakermedia.com and www.reprap.org

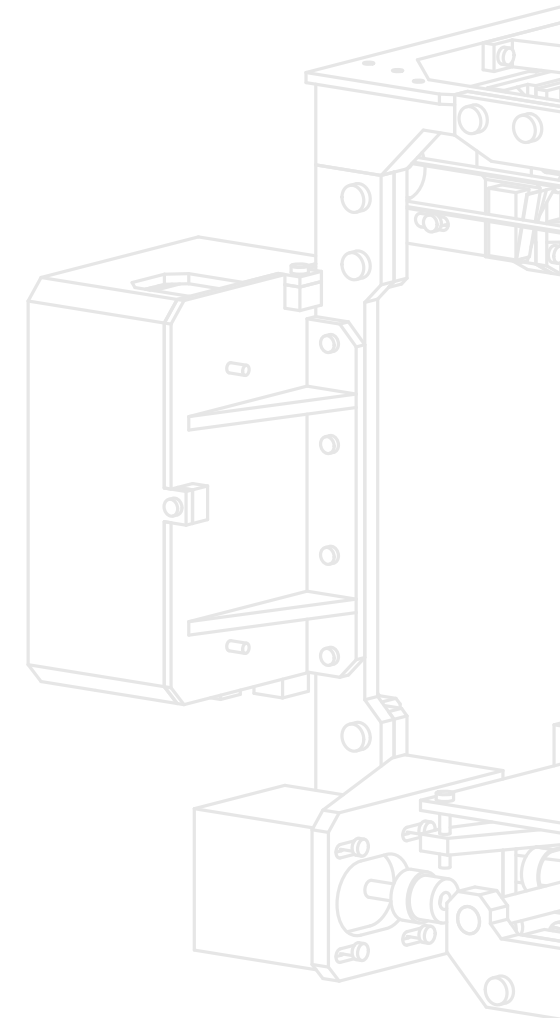



GET IN TOUCH WITH US!

Web: www.maplemakermedia.com

Twitter: [@MapleMakerMedia](https://twitter.com/MapleMakerMedia)

Email: info@maplemakermedia.com

mapleMaker

ADDITIVE ENGINEERING

